



FOLGER ADAM SECURITY INC.
A member of the Yale Security Group



700 Series Parts Manual

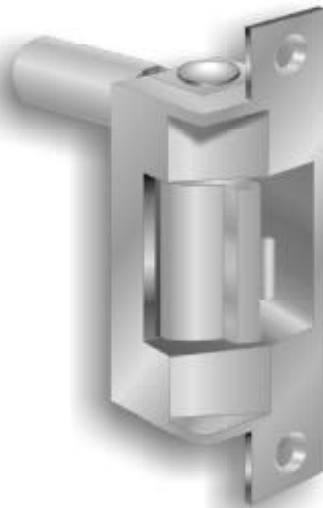

Table of Contents

| | |
|--|----|
| Installation/Operation Instructions | 1 |
| Optional Features..... | 2 |
| Maintenance and Lubrication | 3 |
| Installing and Adjusting Solenoid | 4 |
| Changing Solenoids and Changing Strike Model..... | 5 |
| Instructions for Changing a Solenoid | 6 |
| Instruction for Adding a LCM Switch | 7 |
| Instruction for Adding a LBM Switch | 8 |
| Changing and Replacing the Keeper Illustration | 9 |
| Changing and Replacing the Keeper | 10 |
| Parts List | 11 |
| Parts List | 12 |
| Parts Illustrations..... | 13 |
| Parts List | 14 |
| Repair Parts Kit | 15 |
| Trouble Shooting | 16 |
| Strike Assembly | 17 |
| Strike Assembly | 18 |
| Faceplate Illustrations | 19 |
| Faceplate Part Numbers | 20 |
| Wiring Diagrams..... | 21 |
| Wiring Diagrams..... | 22 |

The following instructions cover all models of the 700 series strike: 710-75, 710, 712-75, 712, 722-75, 722, 730-75, 730, 732-75 and 732.

INSTALLATION

1. For proper installation of the 700 strike refer to the appropriate template drawing.
2. Prior to installation make the necessary wire connections per the appropriate wiring diagram.
3. Proper operating voltage must be supplied to the strike if it is to function correctly. Voltage at the strike must be within + or - 10% of the required voltage listed on the strike label.
4. To install the strike into the frame opening:
 - A) Position the wiring either down or up or toward the back of the hollow metal frame, making sure that it stays completely out of the way of the strike so as not to pinch it when installing.
 - B) Mount the strike using the screws supplied:

| Strike Model | Mounting Screws |
|--------------------------|----------------------------------|
| 712, 712-75, 722, 722-75 | (2) 12-24 x 1/2 FH PHIL MACH SCS |
| 732, 732-75 | (2) 12 X 3/4 FH PHIL WOOD SCS |

5. After installation check the horizontal alignment, be certain that the centerline of the latch bolt is aligned with the centerline of the strike.
6. In case of misalignment there is a 3/16" horizontal adjustment between the strike mechanism and the face plate. To adjust:
 - A) Remove mounting screws.
 - B) Remove strike from frame.
 - C) Loosen the two (2) 8-32 PHPMS.
 - D) Reposition strike and retighten PHPMS screws.
 - E) Reinstall strike in frame.
 - F) Reinstall mounting screws.

OPERATION

The Folger Adam 700 electric strike is a solenoid operated device.

1. **710 NON-FAIL-SAFE**
When power is applied the solenoid pushes the locking cam into the unlocked position allowing the door to be opened. If power fails the strike will remain locked.

NOTE: Non-fail-safe strikes for use in fire rated doors can only be operated by momentary contact switching (energized only when the push button is held depressed) and can not be held in the unlocked position.
2. **710 FAIL-SAFE**
When power is applied the solenoid pushes the locking cam into the locked position and the door can not be opened. If power fails the strike will unlock.
3. **730 NON-FAIL-SAFE**
When power is applied the solenoid pushes the locking cam into the unlocked position allowing the door to be opened. If power fails the strike will remain locked.

NOTE: Non-fail-safe strikes for use in fire rated doors can only be operated by momentary contact switching (energized only when the push button is held depressed) and can not be held in the unlocked position.
4. **730 FAIL-SAFE**
When power is applied the solenoid pulls the locking cam into the locked position and the door can not be opened. If power fails the strike will unlock.



OPTIONAL FEATURES

1. **LBM SWITCH (Latch Bolt Monitor)**
A switch operated by the switch tripper that signals whether or not the latch bolt is extended into the strike.
2. **LCM SWITCH (Locking Cam Monitor)**
A switch operated by the roll pin on the locking cam that monitors the position of the locking cam and signals that the strike is either locked or unlocked.
3. **LBMLCM SWITCH (Locking Cam and Latch Bolt Monitor)**
A combination of the LCM and LBM switches. By wiring these two switches together, externally, they will indicate that the strike is locked (LCM) and the latch bolt is extended (LBM) into the strike.
4. **LCMA SWITCH (Locking Cam and Latch Bolt Monitor)**
Two built-in limit switches. One switch will indicate that the cam is either locked or unlocked (LCM). The other is an auxiliary switch, activated by the latch bolt, to indicate that the latch bolt is extended into the strike (LBM).
5. **SOLENOID VOLTAGE**
24VDC is standard. Optional voltages available are 6, 12, 16, 48, or 115VDC or VAC.

When control power source is AC, the strike is supplied with an externally attached bridge rectifier.

When control power source is DC, the strike is supplied without the bridge rectifier.

NOTE: UL requires that a junction box be used with 48 and 120 volt strikes, if they are not installed in a back box.
6. **FAIL-SAFE**
The strike is locked when energized. This feature should be used for applications that require automatic unlocking in case of power failure.

CAUTION: Fail-safe is not permitted with the UL Fire Door Accessory label.
7. **MOUNTING TAB**
The mounting tab is designed to be used with 712, 712-75, 722 and 722-75 electric strikes when mounting in metal frames.
8. **ASTRAGAL**
A lock guard, designed to prevent tampering with the strike keeper and the latch bolt.
9. **EXTENDED LIP**
A lip extension is added to the face plate to form a path for the latch bolt when released electrically. Extension is available in increments of 1/4" up to 2" maximum.

MAINTENANCE AND LUBRICATION

Under normal usage the 700 electric strike should be cleaned and lubricated once a year to maintain its reliability. In applications with high usage or dirty conditions more frequent service may be necessary. When servicing a 700 inspect the internal parts for excess wear or breakage and lightly lubricate. Lubricate with Lightning Grease, available from Folger Adam. Never lubricate any strike with oil, such lubrication collects dirt and forms an abrasive and sticky compound that may affect the function of the strike.

TO INSPECT AND LUBRICATE THE STRIKE:

1. Remove the strike from the face plate, held on by two (2) 8-32 x 3/8 PHPMS.
2. Remove the front cover, held on by two (2) 4-40 x 3/16 FHMS. Removal of the front cover should be done slowly because the locking cam spring may snap out of place. Also, care should be taken to insure that the baffle is not lost.
3. Remove the cam spring and the baffle.
4. PULL TYPE: Loosen the lock nut holding the solenoid, then remove the solenoid and then the plunger.
 PUSH TYPE: Loosen the lock nut holding the solenoid, then remove the solenoid and plunger assembly.
5. Remove the locking cam.
6. Remove the locking lever spring and locking lever.
7. Lubricate the area in the case where the locking lever and locking cam rest. (Be careful not to get any lubricant on the solenoid or switches.) Lubricate the cam pin and lever pin.
8. Check the locking angle of the keeper and locking lever for wear. Replace the keeper and/or lever if worn. (If the keeper is disassembled for replacement or adding of a switch, lubricate the keeper pin.)
9. Reinstall the locking lever and the locking lever spring, the spring must be held compressed into the hole in the locking lever for installation.
10. Check the solenoid, plunger and plunger guide for excess wear, dirt, grime or oil, if present wipe clean.
 PUSH TYPE: Remove the retaining ring for inspection of the plunger guide. Re-assemble the solenoid and plunger with a new retaining ring.
11. PULL TYPE: Lubricate the roll pin and the locking cam surfaces between the solenoid plunger (contact points of the solenoid plunger).
 PUSH TYPE: Lubricate the edge of the locking cam (contact point of the solenoid plunger).
12. Reinstall the locking cam. If the strike has a LCM, LBMLCM or LCMA switch make sure the roll pin on the locking cam is positioned in front of the switch actuator arm.

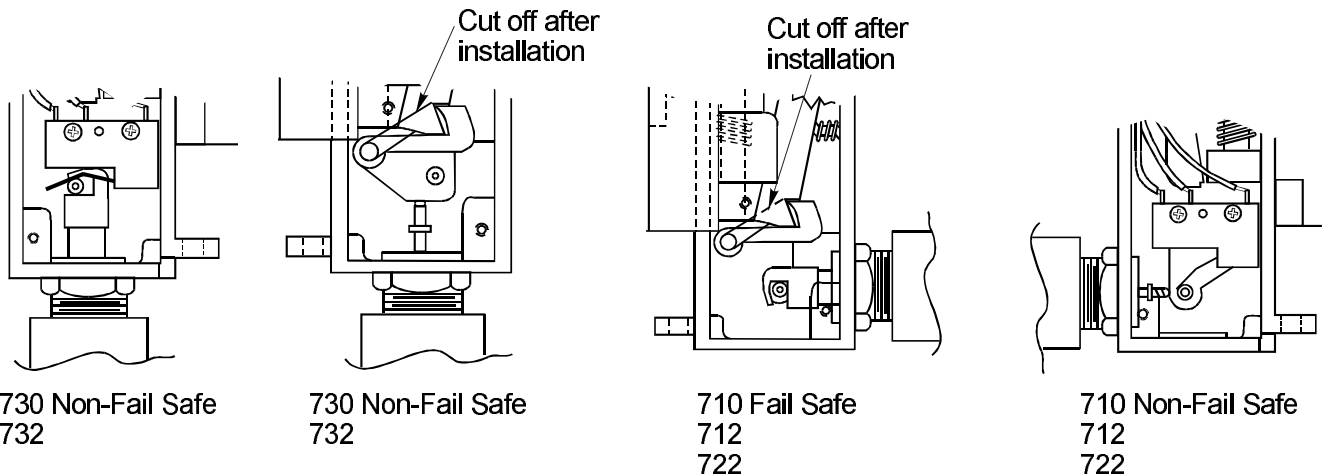

MAINTENANCE AND LUBRICATION

Under normal usage the 700 electric strike should be cleaned and lubricated once a year to maintain its reliability. In applications with high usage or dirty conditions more frequent service may be necessary. When servicing a 700 inspect the internal parts for excess wear or breakage and lightly lubricate. Lubricate with Lightning Grease, available from Folger Adam. Never lubricate any strike with oil, such lubrication collects dirt and forms an abrasive and sticky compound that may affect the function of the strike.

TO INSPECT AND LUBRICATE THE STRIKE:

1. Remove the strike from the face plate, held on by two (2) 8-32 x 3/8 PHPMS.
2. Remove the front cover, held on by two (2) 4-40 x 3/16 FHMS. Removal of the front cover should be done slowly because the locking cam spring may snap out of place. Also, care should be taken to insure that the baffle is not lost.
3. Remove the cam spring and the baffle.
4. PULL TYPE: Loosen the lock nut holding the solenoid, then remove the solenoid and then the plunger.
 PUSH TYPE: Loosen the lock nut holding the solenoid, then remove the solenoid and plunger assembly.
5. Remove the locking cam.
6. Remove the locking lever spring and locking lever.
7. Lubricate the area in the case where the locking lever and locking cam rest. (Be careful not to get any lubricant on the solenoid or switches.) Lubricate the cam pin and lever pin.
8. Check the locking angle of the keeper and locking lever for wear. Replace the keeper and/or lever if worn. (If the keeper is disassembled for replacement or adding of a switch, lubricate the keeper pin.)
9. Reinstall the locking lever and the locking lever spring, the spring must be held compressed into the hole in the locking lever for installation.
10. Check the solenoid, plunger and plunger guide for excess wear, dirt, grime or oil, if present wipe clean.
 PUSH TYPE: Remove the retaining ring for inspection of the plunger guide. Re-assemble the solenoid and plunger with a new retaining ring.
11. PULL TYPE: Lubricate the roll pin and the locking cam surfaces between the solenoid plunger (contact points of the solenoid plunger).
 PUSH TYPE: Lubricate the edge of the locking cam (contact point of the solenoid plunger).
12. Reinstall the locking cam. If the strike has a LCM, LBMLCM or LCMA switch make sure the roll pin on the locking cam is positioned in front of the switch actuator arm.

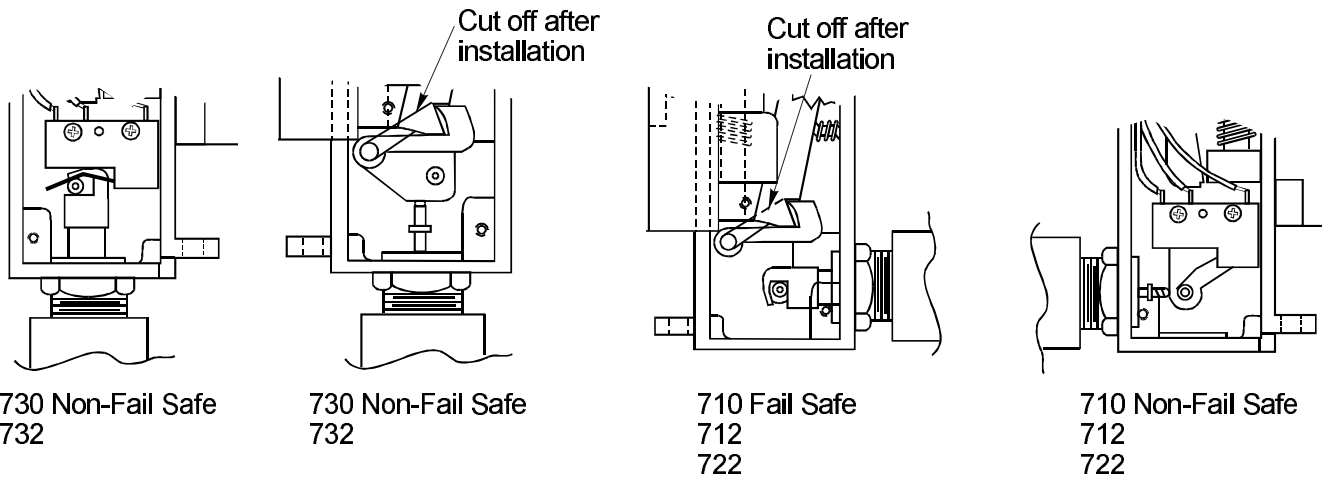

13. INSTALLING AND ADJUSTING THE SOLENOID

A) 710 NON-FAIL-SAFE: In the bottom hole in the case, install the plunger with the opening for the roll pin toward the lever side of the case, then install the solenoid.

730 NON-FAIL-SAFE: In the back hole in the case, install the solenoid and plunger assembly.

710 FAIL-SAFE: In the bottom hole in the case, install the solenoid and plunger assembly.

730 FAIL-SAFE: In the back hole in the case, install the plunger with the opening for the roll pin toward the bottom of the case, then install the solenoid.

B) 710 & 730 NON-FAIL-SAFE: Install the locking cam spring with the L-shaped leg of the spring on the bottom of the locking cam (plunger side) and the other leg in the groove in the side of the case. See illustrations.

710 & 730 FAIL-SAFE: Install the locking cam spring with the L-shaped leg of the spring on the top of the locking cam (locking lever side) and the other leg in the groove in the case (near the locking lever). See illustrations.

C) 710 NON-FAIL-SAFE (Pull Type): Before tightening the lock nut, energize the solenoid and adjust the solenoid position until the locking cam is pulled into the unlocked position, tighten the lock nut on the solenoid.

710 FAIL-SAFE (Push Type): Before tightening the lock nut, energize the solenoid and adjust the solenoid position until the solenoid plunger pushes the locking cam into the locked position (do not screw in the solenoid more than required or the solenoid plunger will not seat in the solenoid). De-energize the solenoid and check that the locking cam moves to the unlocked position. Tighten the solenoid lock nut.

730 NON-FAIL-SAFE (Push Type): Before tightening the lock nut, energize the solenoid and adjust the solenoid position until the solenoid plunger pushes the locking cam into the unlocked position, tighten the lock nut on the solenoid.

730 FAIL-SAFE (Pull Type): Before tightening the lock nut, energize the solenoid and adjust the solenoid position until the locking cam is pulled into the locked position. De-energize the solenoid and check that the locking cam moves to the unlocked position, tighten the solenoid lock nut.

HINT: Hold cam spring in place or place cover over cam spring before energizing solenoid.

14. Check all screws, tighten if necessary. CAUTION: Do not over tighten the switch screws, over tightening could break the switch.
15. Reinstall the baffle.
16. Reinstall the front cover.
17. Re-assemble the strike to the face plate.

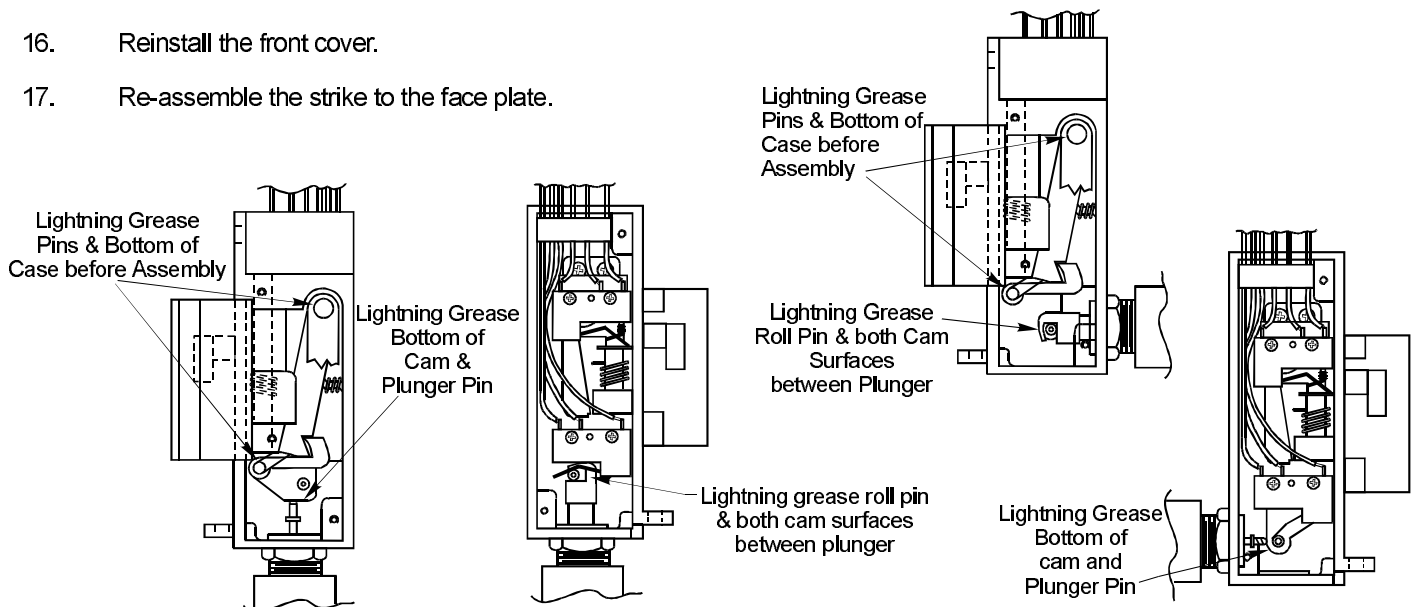



CHANGING SOLENOIDS AND CHANGING STRIKE MODEL

(FS to NON-FS, NON-FS to FS) (710 to 730, 730 to 710)

NOTE: PUSH TYPE solenoids are used in 710 FAIL-SAFE and 730 NON-FAIL-SAFE strikes.
PUSH TYPE solenoids are used in 710 NON-FAIL-SAFE and 730 FAIL-SAFE strikes.

NOTE: To change from DC to AC a rectifier (item 4, listed below) must be connected to the solenoid with butt splices.
To change from AC to DC remove the rectifier by cutting the wire leads.

| PARTS: | ITEM | DESCRIPTION | QTY | PART NUMBER |
|--------|------|-------------------------------|-----|--------------|
| | 1A | CamSpring Fail-Safe 710 & 730 | | 003-0209-001 |
| | 1B | Cam Spring Non-Fail-Safe 710 | 1 | 003-0208-001 |
| | 1C | Cam Spring Non-Fail-Safe 730 | | 003-0202-001 |
| | 2A | Solenoid Assy Pull 6VDC | 1 | 076-0107-001 |
| | | Solenoid Assy Pull 12VDC | | 076-0107-002 |
| | | Solenoid Assy Pull 16VDC | | 076-0107-003 |
| | | Solenoid Assy Pull 24VDC | | 076-0107-004 |
| | | Solenoid Assy Pull 48VDC | | 076-0107-005 |
| | | Solenoid Assy Pull 115VDC | | 076-0107-006 |
| | 2B | Solenoid Assy Push 6VDC | 1 | 076-0106-001 |
| | | Solenoid Assy Push 12VDC | | 076-0106-002 |
| | | Solenoid Assy Push 16VDC | | 076-0106-003 |
| | | Solenoid Assy Push 24VDC | | 076-0106-004 |
| | | Solenoid Assy Push 48VDC | | 076-0106-005 |
| | | Solenoid Assy Push 115VDC | | 076-0106-006 |
| | 3A | Locking Cam Assy 710 | 1 | 076-0200-001 |
| | 3B | Locking Cam Assy 730 | 1 | 076-0201-001 |
| | 4 | Rectifier for AC | 1 | 076-0710-001 |

INSTRUCTIONS FOR CHANGING A:

710 NFS to a 710 FS (new solenoid and cam spring required, Items 1A and 2B)
710 FS to a 710 NFS (new solenoid and cam spring required, Items 1B and 2A)
730 NFS to a 730 FS (new solenoid and cam spring required, Items 1A and 2A)
730 FS to a 730 NFS (new solenoid and cam spring required, Items 1C and 2B)

1. Remove the strike from the face plate, held on by two (2) 8-32 x 3/8 PHPMS.
2. Remove the front cover, held on by two (2) 4-40 x 3/16 FHMS. Removal of the front cover should be done slowly because the locking cam spring may snap out of place. Also care should be taken to insure that the baffle is not lost.
3. Remove the cam spring and the baffle.
4. PULL TYPE: Loosen the lock nut holding the solenoid, then remove the solenoid and then the plunger.
PUSH TYPE: Loosen the lock nut holding the solenoid, then remove the solenoid and plunger assembly.
5. Refer to the instructions for INSTALLING AND ADJUSTING THE SOLENOID (see drawing 089-0250-005, page 2, Item 13).
6. Reinstall the baffle.
7. Reinstall the front cover.
8. Re-assemble the strike to the face plate.
9. Refer to the appropriate wiring diagram for wire connections.

700 Strike

700 Series Parts



FOLGER ADAM SECURITY INC.
A member of the Yale Security Group

INSTRUCTIONS FOR CHANGING A:

710 NFS to a 730 FS (same solenoid, new cam and cam spring, Items 1A and 3B)

710 NFS to a 730 NFS (new solenoid, cam and cam spring, Items 1C, 2B and 3B)

710 FS to a 730 FS (new solenoid and cam, same cam spring, Items 2A and 3B)

710 FS to a 730 NFS (same solenoid, new cam and cam spring, Items 1C and 3B)

1. Remove the strike from the face plate, held on by two (2) 8-32 x 3/8 PHPMS.
2. Remove the front cover, held on by two (2) 4-40 x 3/16 FHMS. Removal of the front cover should be done slowly because the locking cam spring may snap out of place. Also care should be taken to insure that the baffle is not lost.
3. Remove the cam spring and the baffle.
4. PULL TYPE: Loosen the lock nut holding the solenoid, then remove the solenoid and then the plunger. Remove the locking cam.

PUSH TYPE: Loosen the lock nut holding the solenoid, then remove the solenoid and plunger assembly. Remove the locking cam.
5. Remove the hole plug and reinstall it in the opposite hole in the case (bottom).
6. A) Lubricate the area in the case where the locking cam rests. Lubricate the cam pin.
B) Lubricate the edge of the locking cam (contact point of the solenoid plunger).
NOTE: Apply lubricant very lightly!! Be careful not to get any lubricant on the solenoid or switches.
C) Install the new locking cam. Make sure that the locking cam does not drag. If the strike has a LCM, LBMLCM, or LCMA switch make sure the roll pin on the locking cam is positioned in front of the switch acuator arm.
7. Refer to the instructions for INSTALLING AND ADJUSTING THE SOLENOID.
8. Reinstall the baffle.
9. Reinstall the front cover.
10. Re-assemble the strike to the face plate.
11. Refer to the appropriate wiring diagramfor wire connections.

INSTRUCTIONS FOR CHANGING A:

730 FS to a 710 FS (new solenoid and cam, same cam spring, Items 2B and 3A)

730 FS to a 710 NFS (same solenoid, new cam and cam spring, Items 1B and 3A)

730 NFS to a 710 NFS (new solenoid, cam and cam spring, Items 1B, 2A and 3A)730 NFS to a 710 FS (same solenoid, new cam and cam spring, Items 1A and 3A)

1. Remove the strike from the face plate, held on by two (2) 8-32 x 3/8 PHPMS.
2. Remove the front cover, held on by two (2) 4-40 x 3/16 FHMS. Removal of the front cover should be done slowly because the locking cam spring may snap out of place. Also care should be taken to insure that the baffle is not lost.
3. Remove the cam spring and the baffle.
4. PULL TYPE: Loosen the lock nut holding the solenoid, then remove the solenoid and then the plunger. Remove the locking cam.

PUSH TYPE: Loosen the lock nut holding the solenoid, then remove the solenoid and plunger assembly. Remove the locking cam.
5. Remove the hole plug and reinstall it in the opposite hole in the case (back).
6. A) Lubricate the area in the case where the locking cam rests. Lubricate the cam pin.
B) Lubricate the edge of the locking cam (contact point of the solenoid plunger).
NOTE: Apply lubricant very lightly!! Be careful not to get any lubricant on the solenoid or switches.
C) Install the new locking cam. Make sure that the locking cam does not drag. If the strike has a LCM, LBMLCM or LCMA switch make sure the roll pin on the locking cam is positioned in front of the switch actuator arm.
7. Refer to the instructions for INSTALLING AND ADJUSTING THE SOLENOID.
8. Reinstall the baffle.
9. Reinstall the front cover.
10. Re-assemble the strike to the face plate.
11. Refer to the appropriate wiring diagram for wire connections.

Instruction For Adding a LCM Switch

| PARTS REQUIRED: | Description | Qty | Part Number |
|------------------------|----------------------|------------|--------------------|
| | LCM Switch Assembly | 1 | 076-1203-001 |
| | Switch Insulator | 1 | 005-0719-001 |
| | RHMS 2-56 x 3/8 Zinc | 2 | 002-2100-133 |
| | Strain Relief Insert | 1 | 005-4905-001 |

1. Remove the strike from the face plate, held on by (2) 8-32 x 3/8 PHPMS.
2. Remove the back cover by loosening the two (2) 4-40 x 3/16 PHMS. If the strike has a LBM switch care should be taken to insure that the strain relief is not lost, remove the strain relief.
3. Bend the switch actuator arm per the illustration, before installation. Install the switch and insulator with the roll pin on the locking cam in front of the switch actuator arm. Secure the switch in place with the two (2) 2-56 x 3/8 RHMS. The switch actuator arm must be adjusted to actuate when the locking cam is in the locked position. See illustration. Reposition the wires and fasten the insulator over the switch.
4. Install the strain relief insert.
5. Reinstall the back cover.
6. Reassemble the strike to the face plate.
7. Refer to the appropriate wiring diagram for wire connections.

Rear View Shown
with LCM Switch

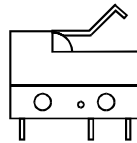
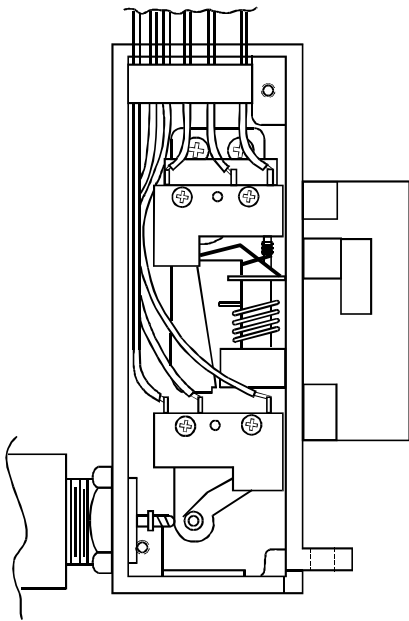

Rear View Shown
with LBM Switch

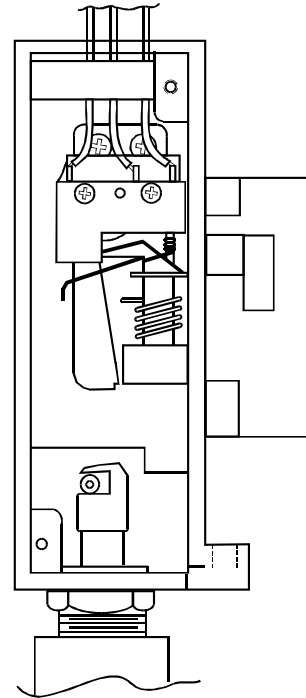

INSTRUCTION FOR ADDING A LBMLCM SWITCH

Refer to instructions for adding LCM and LBM switches. Increase the quantity of switch insulators to two (2).



Instruction For Adding a LBM Switch

Special Tool Required: Keeper Spring Tool, 007-0010-001

| | <u>Description</u> | <u>Qty</u> | <u>Part Number</u> |
|---|--|------------|--------------------|
| PARTS REQUIRED: | LBM Switch Assembly | 1 | 076-1202-001 |
| | Switch Tripper Spring | 1 | 003-0207-001 |
| | Switch Insulator | 1 | 005-0719-001 |
| | FHMS 2-56 x 3/8 Zinc | 2 | 002-1900-361 |
| | Switch Mounting Bracket | 1 | 008-0602-001 |
| | FHMS 4-40 x 3/8 SST | 2 | 002-1900-387 |
| | Keeper for Switch 1/2 700 | | 012-0608-001 |
| | Keeper for Switch 3/4 700-75 | | 012-0614-001 |
| | Strain Relief Insert | 1 | 005-4905-001 |
| | <u>Switch Tripper for 700-75 Strikes 1/2-5/8 Bolts</u> | | |
| | Switch Tripper 1/2-5/8 Bolts | 1 | 012-0619-001 |
| <u>Switch Tripper for 700 Strikes 1/2-5/8 bolts or 700-75 Strikes 3/4 Bolts</u> | | | |
| | Switch Tripper 3/4 Bolts | 1 | 012-0609-001 |

1. Remove the strike from the face plate, held on by two (2) 12-24 x 3/8 HEX WASHER HEAD CAP SCS.
2. Remove the front cover, held on by two (2) 4-40 x 3/16 FHMS. Removal of the front cover should be done slowly because the locking cam spring may snap out of place. Also, care should be taken to insure that the baffle is not lost.
3. Remove the cam spring and the baffle.
4. PULL TYPE: Loosen the lock nut holding the solenoid, then remove the solenoid and then the plunger.
5. Remove the locking cam.
6. Remove the back cover by loosening the two (2) 4-40 x 3/16 PHMS. If the strike has a LCM switch, care should be taken to insure that the strain relief is not lost, remove the strain relief.
7. Change the keeper (see instructions for CHANGING AND REPLACING THE KEEPER).
8. Install the switch mounting bracket with the two (2) 4-40 x 3/16 FHMS.
9. Bend the switch actuator arm per the illustration, before installation. Install the switch and insulator on the switch mounting bracket with the actuator arm in behind the switch tripper leg. Tighten the switch mounting screws. The switch actuator arm must be adjusted to actuate when the switch tripper is rotated away from the keeper, see illustration. Reposition the wires and fasten the insulator over the switch.
10. Install the strain relief insert.
11. Reinstall the back cover.
12. Reinstall the locking cam. If the strike has a LCM, LBMLCM or LCMA switch make sure the roll pin on the locking cam is positioned in front of the switch actuator arm.
13. Refer to the instructions for INSTALLING AND ADJUSTING THE SOLENOID.
14. Reinstall the baffle.
15. Reinstall the front cover.
16. Reassemble the strike to the face plate.
17. Refer to the appropriate wiring diagram for wire connections.

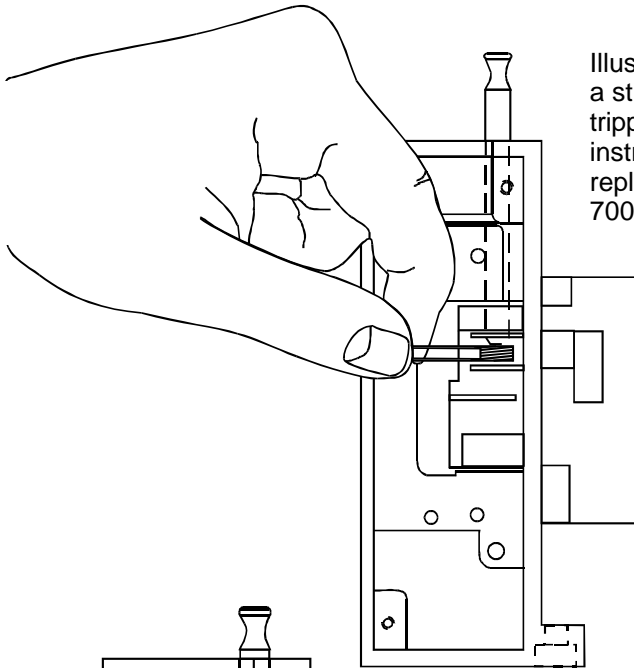
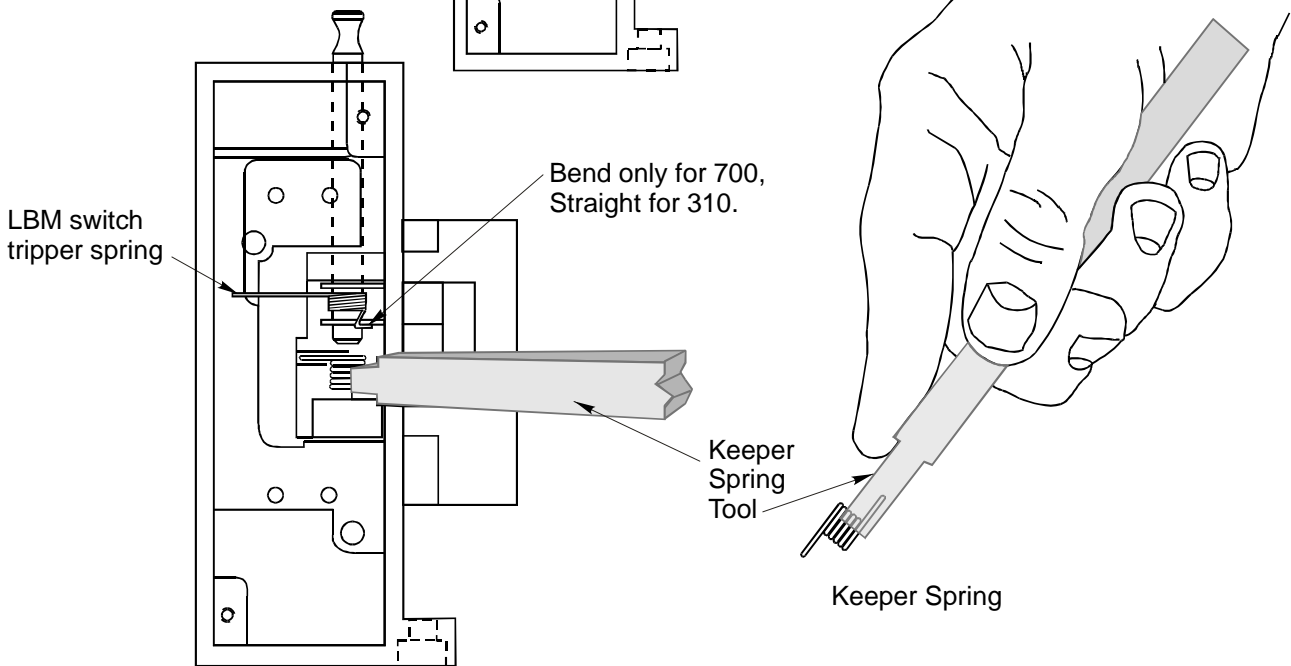

Illustration showing the assembly of a strike keeper and LBM switch tripper. Illustration is to be used with instructions for changing and replacing keepers in the 310 and 700 repair parts manual.



To remove a 310 Strike Knurled Keeper Pin:

- 1) Using a punch and hammer, Place the punch against the bottom of the keeper pin (as shown below).
- 2) Tap the keeper pin out of the case until the knurled portion of the pin is outside of the case.
- 3) Pull the keeper pin out with pliers.

If the 310 strike has a set screw to hold the keeper pin in place. Loosen the set screw and push the keeper pin out of the case.

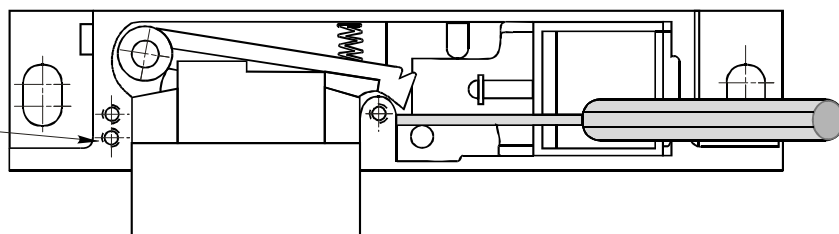



CHANGING AND REPLACING THE KEEPER

Special tool Required: Keeper Spring Tool, 007-0010-001

Note: During the first quarter of 1987 a change was made to the case and keeper pin. One radius groove was removed from the keeper pin. One of the cover mounting holes was relocated on the case. Strikes produced after the fourth quarter of 1986 have changes made to the case and keeper pin.

1. TO REMOVE THE KEEPER:

- A) Loosen the SSSC holding the keeper pin.
- B) Push the keeper out of the case from the bottom (near the cam pin) until the end of the pin is outside of the case at the top of the strike.
- C) The keeper pin can then be pulled out with pliers.

2. TO INSTALL A KEEPER, use the instructions listed below:

- A) Lubricate the keeper pin and both hubs of the keeper, the contact areas with the case walls.
- B) KEEPER WITH A SWITCH TRIPPER: Lubricate both hubs of the switch tripper.
- C) Position the keeper in the case and insert the keeper pin (through the hole in the top of the case) through the first hub of the keeper.
- D) KEEPER WITH A SWITCH TRIPPER: Position the switch tripper in the case and push the keeper pin (through the hole in the top of the case) through the first hub of the keeper.
- E) KEEPER WITH A SWITCH TRIPPER: With the switch tripper spring legs bent toward the circle of the spring, insert the switch tripper spring and push the keeper pin through the switch tripper spring and the second hub of the switch tripper.
- F) Cut approximately 1/8" off one leg of the keeper spring. Using the keeper spring tool insert the long leg of the keeper spring into the tool, then push the keeper spring into position in the keeper with the short leg of the keeper spring positioned in the slot in the keeper.
- G) Push the keeper pin through the spring, the second hub of the keeper, then into the hole in the cases until flush.
- H) Tighten the SSSC to secure the keeper pin.
- I) KEEPER WITH A SWITCH TRIPPER: Bend the leg of the switch tripper spring near the lever, approximately 3/8" from the end of the leg, into a L-shape. Pull up the other leg and bend it around the switch tripper, then cut approximately 7/8" off.



| Item | Description | Part Number |
|-------------|----------------------------------|--------------------|
| 1 | Case Assembly | 076-0007-001 |
| 4A | Locking Cam Assembly 710-720 | 076-0200-001 |
| 4B | Locking Cam Assembly 730 | 011-0201-001 |
| 5 | Locking Lever | 011-0612-001 |
| 6 | Latch Keeper Pin | 011-0600-001 |
| | Latch Keeper Pin w/notch | 011-0603-001 |
| 7 | Locking Cam Pin | 011-0601-001 |
| 8 | Locking Lever Pin | 011-0602-001 |
| 9 | Front Cover Plate Old Style | 008-0600-001 |
| | Front Cover Plate | 008-0605-001 |
| 10 | Back Cover Plate | 008-0601-001 |
| 11 | Latch Keeper Spring | 003-0256-001 |
| 12 | Switch Tripper Spring | 003-0207-001 |
| 13A | Locking Cam Spring FS 710 FS 730 | 003-0209-001 |
| 13B | Locking Cam Spring NFS 710 | 003-0208-001 |
| 13C | Locking Cam Spring NFS 730 | 003-0202-001 |
| 14 | Compression Spring-Lever | 003-0007-001 |
| 15 | Baffle | 008-0603-001 |
| 16 | Switch Mounting Bracket | 008-0602-001 |
| 17 | Strain Relief Insert | 005-4905-001 |
| 18 | Switch Assembly LBM | 076-1202-001 |
| 19 | Switch Assembly LCM | 076-1203-001 |
| 20 | Switch Insulator | 005-0719-001 |
| 21 | FHPMS 4-40 x 3/16 UC SST | 002-2301-001 |
| 23 | PHPMS 4-40 x 3/16 SST | 002-2303-387 |
| 25 | PHPMS 2-56 x 3/8 Zinc | 002-2303-133 |

KEEPERS AND SWITCH TRIPPERS

| Item | Description | Part Number |
|-------------|----------------------------------|--------------------|
| 2A | Latch Keeper 3/4 | 012-0613-001 |
| 2B | Latch Keeper 3/4 w/Switch option | 012-0614-001 |
| 2C | Latch Keeper 1/2 | 012-0607-001 |
| 2D | Latch Keeper 1/2 w/Switch option | 012-0608-001 |
| 3A | Switch Tripper 1/2-5/8 Bolts | 012-0619-001 |
| 3B | Switch Tripper 3/4 Bolts | 012-0609-001 |

700 Strike 700 Series Parts



FOLGER ADAM SECURITY INC.
A member of the Yale Security Group

| Item | Description | Part Number |
|------|-------------------------------------|--------------|
| 26 | Solenoid Assembly Pull 6VDC | 076-0107-001 |
| | Solenoid Assembly Pull 12VDC | 076-0107-002 |
| | Solenoid Assembly Pull 16VDC | 076-0107-003 |
| | Solenoid Assembly Pull 24VDC | 076-0107-004 |
| | Solenoid Assembly Pull 48VDC | 076-0107-005 |
| | Solenoid Assembly Pull 115VDC | 076-0107-006 |
| 27 | Solenoid Assembly Push 6VDC | 076-0106-001 |
| | Solenoid Assembly Push 12VDC | 076-0106-002 |
| | Solenoid Assembly Push 16VDC | 076-0106-003 |
| | Solenoid Assembly Push 24VDC | 076-0106-004 |
| | Solenoid Assembly Push 48VDC | 076-0106-005 |
| | Solenoid Assembly Push 115VDC | 076-0106-006 |
| 28 | Rectifier AY-310 48-120V/700 0-120V | 076-0710-001 |
| 29 | PHPMS 8-32 x 3/8 Zinc | 002-2303-375 |
| 31 | Connector Plug | 005-1705-001 |
| 32 | Connector Contact Pin | 005-1707-001 |
| 33 | Field Receptacle Assembly | 075-3513-001 |
| 34 | Washer No.8 Ext Tooth Zinc | 010-0098-500 |
| 35 | Hole Plug 7/16 | 005-1202-001 |
| | KEEPERS AND SWITCH TRIPPERS | |
| 2A | Latch Keeper 3/4 | 012-0613-001 |
| 2B | Latch Keeper 3/4 w/Sw Opt | 012-0613-001 |
| 2C | Latch Keeper 1/2 | 012-0613-001 |
| 2D | Latch Keeper 1/2 w/Sw Opt | 012-0613-001 |
| 3A | Switch Tripper 1/2-5/8 Bolts | 012-0609-001 |
| 3B | Switch Tripper 3/4 Bolts | 012-0609-001 |

KEEPER AND SWITCH TRIPPER NOTE:

Items 2A, 2B, & 3A used on 700-75 strikes with 1/2-5/8 bolts.

Items 2A, 2B, & 3B used on 700-75 strikes with 3/4 bolts.

Items 2C, 2D, & 3B used on 700 strikes with 1/2-5/8 bolts.

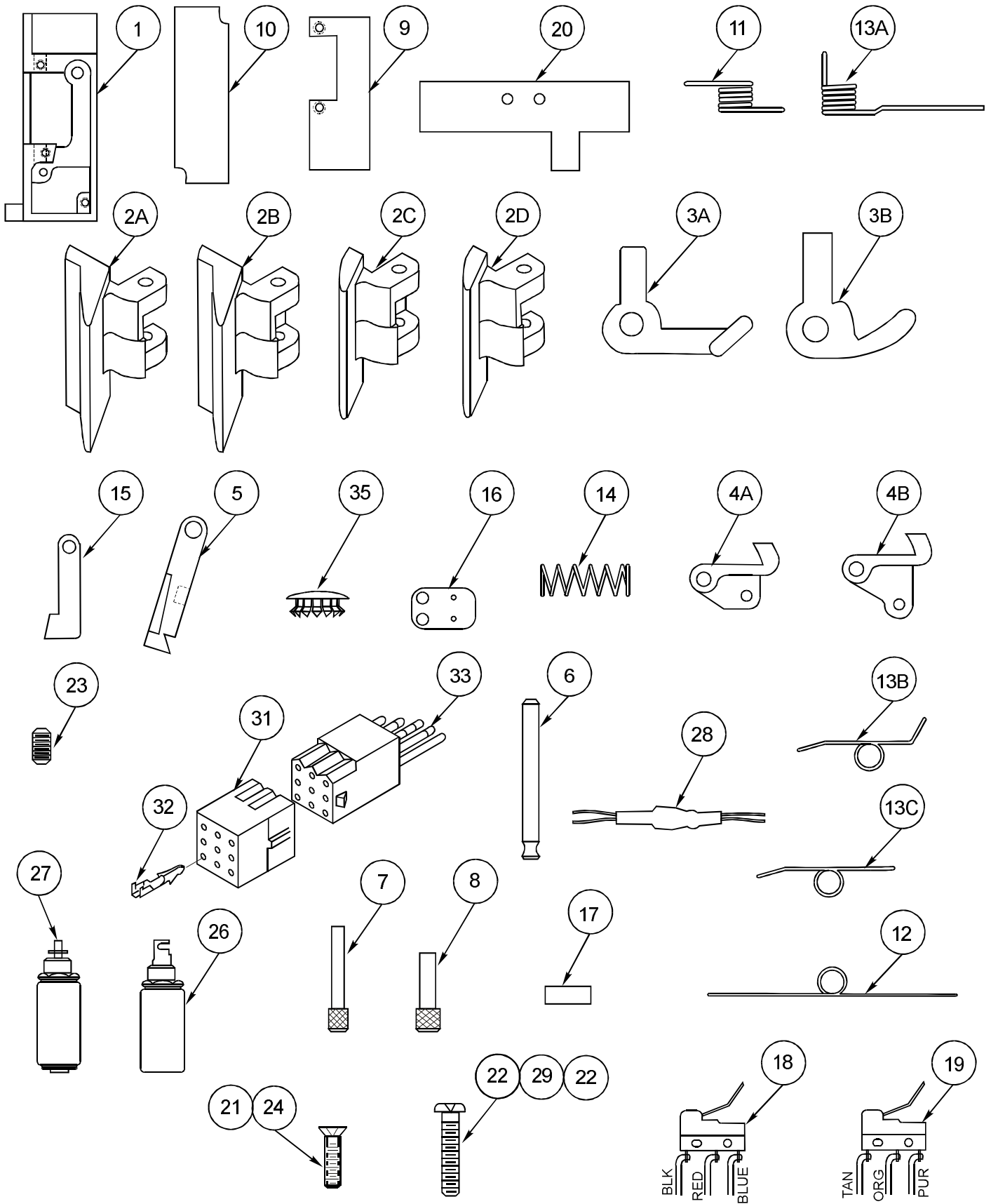

700 Strike 700 Series Parts



FOLGER ADAM SECURITY INC.

| Item | Description | Part Number |
|------|-------------------------------------|--------------|
| 1 | Case Assembly | 076-0007-001 |
| 4A | Locking Cam Assembly 710-720 | 076-0200-001 |
| 4B | Locking Cam Assembly 730 | 011-0201-001 |
| 5 | Locking Lever | 011-0612-001 |
| 6 | Latch Keeper Pin | 011-0600-001 |
| | Latch Keeper Pin w/notch | 011-0603-001 |
| 7 | Locking Cam Pin | 011-0601-001 |
| 8 | Locking Lever Pin | 011-0602-001 |
| 9 | Front Cover Plate Old Style | 008-0600-001 |
| | Front Cover Plate | 008-0605-001 |
| 10 | Back Cover Plate | 008-0601-001 |
| 11 | Latch Keeper Spring | 003-0256-001 |
| 12 | Switch Tripper Spring | 003-0207-001 |
| 13A | Locking Cam Spring FS 710 FS 730 | 003-0209-001 |
| 13B | Locking Cam Spring NFS 710 | 003-0208-001 |
| 13C | Locking Cam Spring NFS 730 | 003-0202-001 |
| 14 | Compression Spring-Lever | 003-0007-001 |
| 15 | Baffle | 008-0603-001 |
| 16 | Switch Mounting Bracket | 008-0602-001 |
| 17 | Strain Relief Insert | 005-4905-001 |
| 18 | Switch Assembly LBM | 076-1202-001 |
| 19 | Switch Assembly LCM | 076-1203-001 |
| 20 | Switch Insulator | 005-0719-001 |
| 21 | FHPMS 4-40 x 3/16 UC SST | 002-2301-001 |
| 23 | PHPMS 4-40 x 3/16 SST | 002-2303-387 |
| 25 | PHPMS 2-56 x 3/8 Zinc | 002-2303-133 |
| 26 | Solenoid Assembly Pull 6VDC | 076-0107-001 |
| | Solenoid Assembly Pull 12VDC | 076-0107-002 |
| | Solenoid Assembly Pull 16VDC | 076-0107-003 |
| | Solenoid Assembly Pull 24VDC | 076-0107-004 |
| | Solenoid Assembly Pull 48VDC | 076-0107-005 |
| | Solenoid Assembly Pull 115VDC | 076-0107-006 |
| 27 | Solenoid Assembly Push 6VDC | 076-0106-001 |
| | Solenoid Assembly Push 12VDC | 076-0106-002 |
| | Solenoid Assembly Push 16VDC | 076-0106-003 |
| | Solenoid Assembly Push 24VDC | 076-0106-004 |
| | Solenoid Assembly Push 48VDC | 076-0106-005 |
| | Solenoid Assembly Push 115VDC | 076-0106-006 |
| 28 | Rectifier AY-310 48-120V/700 0-120V | 076-0710-001 |
| 29 | PHPMS 8-32 x 3/8 Zinc | 002-2303-375 |
| 31 | Connector Plug | 005-1705-001 |
| 32 | Connector Contact Pin | 005-1707-001 |
| 33 | Field Receptacle Assembly | 075-3513-001 |
| 34 | Washer No.8 Ext Tooth Zinc | 010-0098-500 |
| 35 | Hole Plug 7/16 | 005-1202-001 |



FOLGER ADAM SECURITY INC.
A member of the Yale Security Group

700 Strike 700 Series Parts

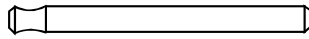
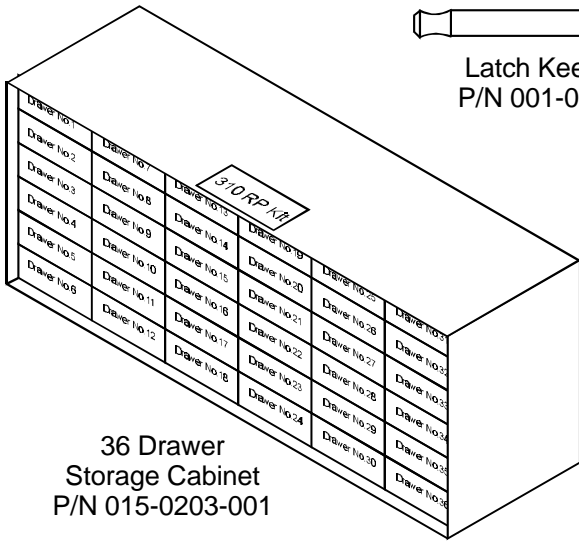

Latch Keeper Pin
P/N 001-0603-001

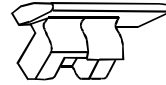

Keeper-LBM 3/4
P/N 012-0614-001

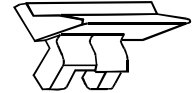

Keeper-LBM
P/N 012-0608-001

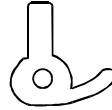

Switch Tripper
700-75 3/4 Bolts 700 1/2-5/8 Bolts
P/N 012-0609-001

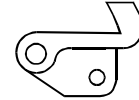

Locking Cam Assy 710
P/N 076-0200-001

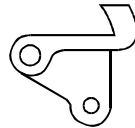

Locking Cam Assy 730
P/N 076-0200-001

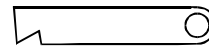

Locking Lever
P/N 012-0612-001

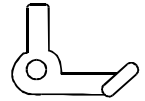

Switch Tripper
700-75 1/2-5/8 Bolts
P/N 012-0619-001



Switch Tripper Spring
P/N 003-0207-001

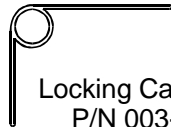

Locking Cam Spring-FS
P/N 003-0209-001



Switch Tripper Spring
P/N 003-0207-001



Locking Cam Spring 730-FL
P/N 003-0202-001



4-40X3/16 SOC SSC
P/N 002-1200-005



2-56 3/8 FHPMS
002-2301-361



4-40x3/16 FHPMS
P/N 002-2301-387



4-40x3/16 PHPMS
P/N 002-2303-024



Keeper Spring
P/N 003-0256-001

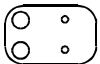

Switch Mntg Bracket
P/N 076-0710-001

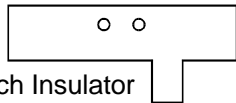

Switch Insulator
P/N 005-0719-001
P/N 002-2301-031 US4
P/N 002-2301-035 U26D



Compression Spring
P/N 003-0007-001

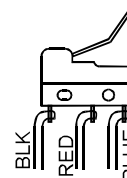

Switch-LCM
P/N 076-1203-001

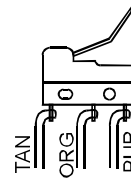

Switch-LBM
P/N 076-1202-001



Solenoid Assy- Pull Type
P/N 076-0107-002



Solenoid Assy- Pull Type
P/N 076-0107-004

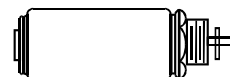

Solenoid Assy- Push Type
12VDC
P/N 076-0106-002



Solenoid Assy- Push Type
24VDC
P/N 076-0106-002

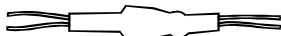

Rectifier Assy - 700
48-120V
P/N 076-0712-012



FHPMS 12-24 x 1/2 UC



2-56 x 3/8 PHPMS
P/N 002-2303-133

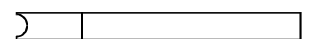

Spring Tool
P/N 007-0010-001



TROUBLE SHOOTING

PROBLEM

Strike does not operate when energized.

Strike operates intermittently.

Solenoid overheating or burned out.

Strike is not re-locking or is not unlocking.

Improper indication.
(LCM, LBM, LBMLCM OR LCMA)

Solenoid plunger binding
(Plunger will not extend or retract).

SOLUTION

Check for proper voltage being supplied to the strike.
Check all wiring.
Check the coil resistance of the solenoid and compare it to the chart located on the wiring diagram, to insure the correct solenoid is being used.

Check for loose wire connection.

Check for proper voltage being supplied to the strike.

Check for proper alignment between strike keeper and bolt, realign face plate if necessary.
The keeper may not be returning to the fully locked position.
Check the strike with the door open, if the strike re-locks check the horizontal alignment between the strike keeper and the latch bolt. There is a 3/16" horizontal adjustment between the strike assembly and the face plate (see installation instructions for adjustment). If vertical alignment is off, reposition the face plate.

Check the locking cam spring to insure it is moving the locking cam into the locked position (non-fail-safe) or the unlocked position (fail-safe).

Check the solenoid assembly to insure the solenoid plunger is moving freely.

Check wiring.
Check latch bolt for correct engagement with switch tripper.
Check switch actuator arm, re-bend if necessary.
Check continuity of indication switches, common to normally open, common to normally closed.

Check alignment between solenoid plunger and cam.

700 Strike assembly

710 Strike

Front View
Push Type Solenoid / FS

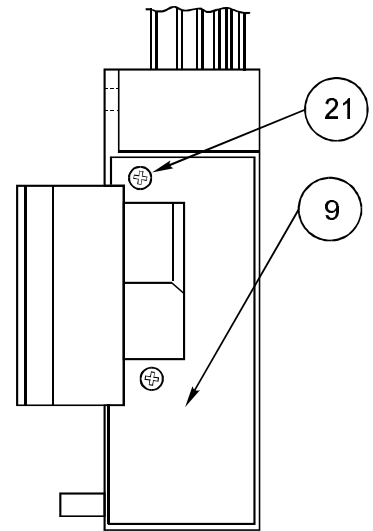
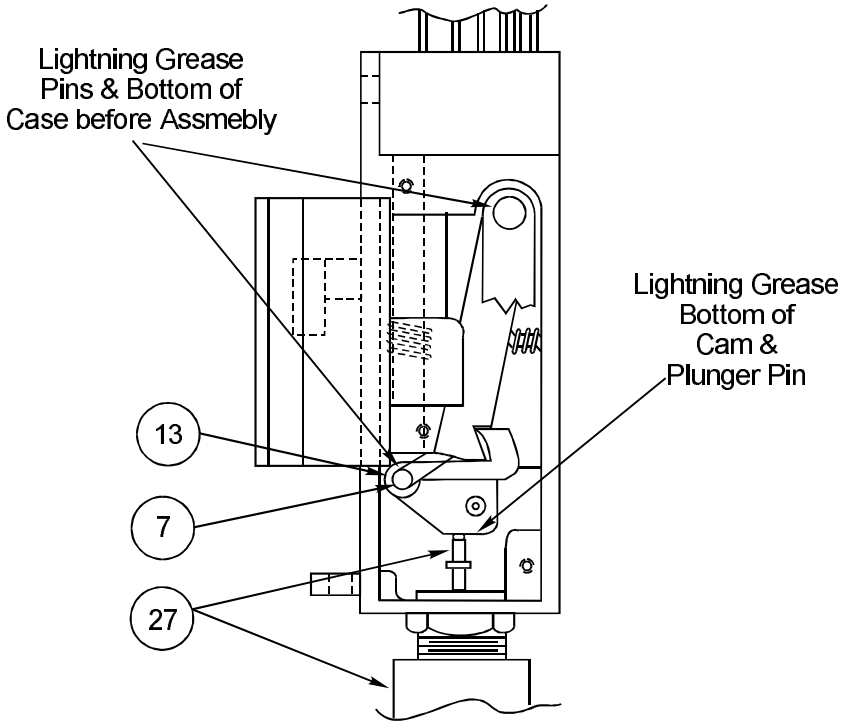

700-75 Strikes Shown
with 3/4 Latch Keeper and
Switch Tripper for 3/4 Bolts

Back View Pull Type Sol / FL
LBM-LCM

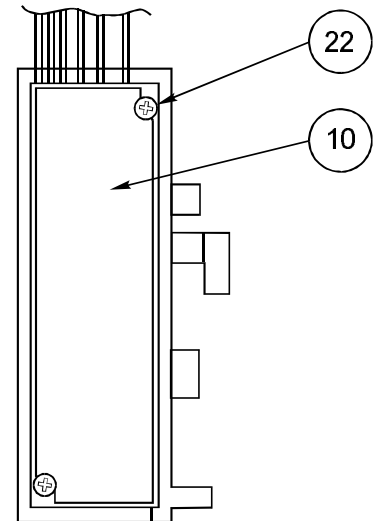
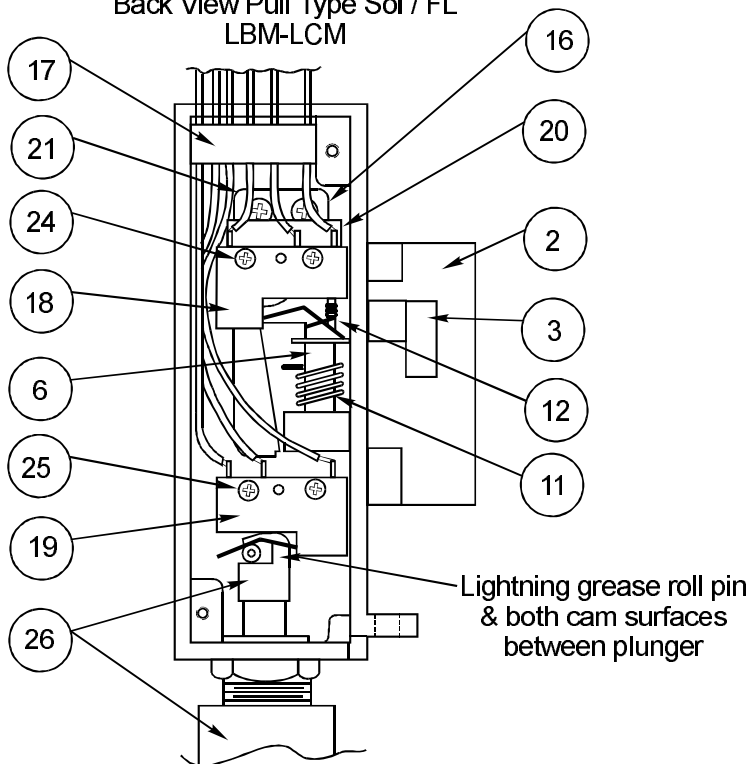

700 Strike assembly

730 Strike

Front View
Push Type Solenoid / FS

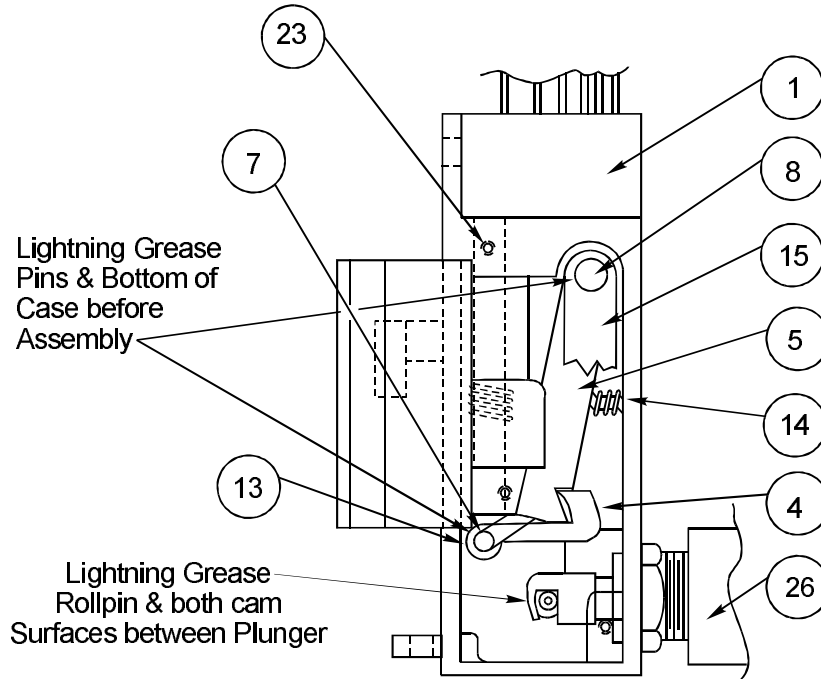

Back View Push Type Sol.fl.
LBM-LCM / LCMA Switch

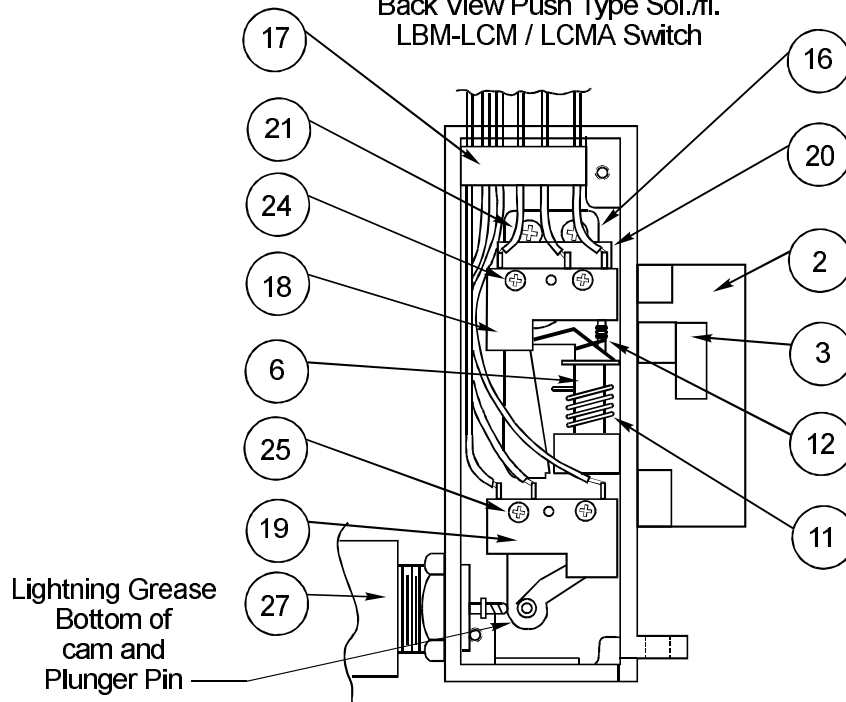

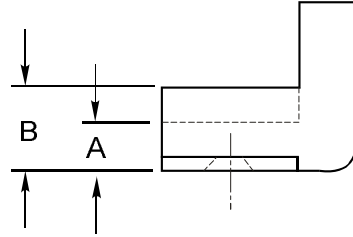
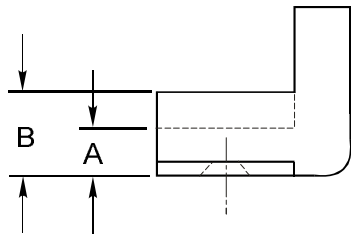

| | |
|--------|-------|
| 712 | A=.50 |
| 722 | |
| 732 | |
| 712-75 | B=.75 |
| 722-75 | |
| 725-75 | |

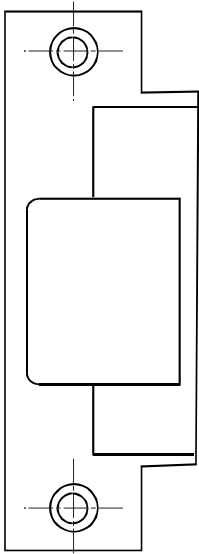

712/732
Faceplate

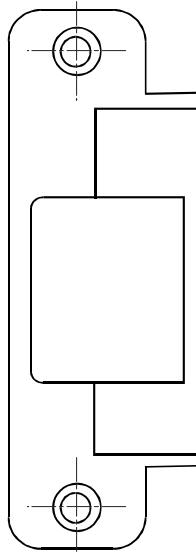

722
Faceplate

 Junction Box
Hole Plug

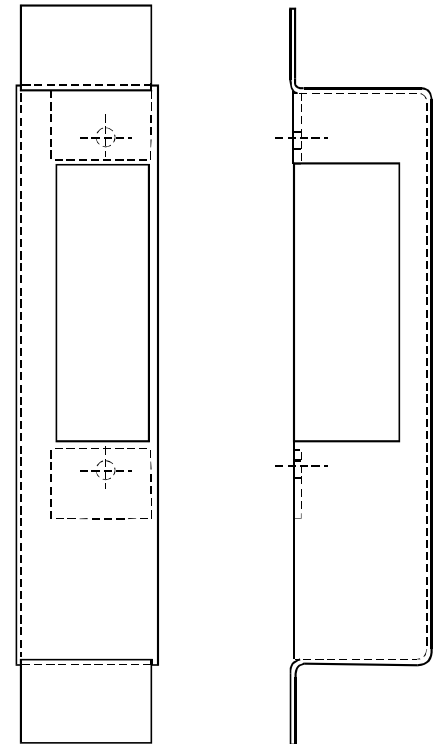

Junction Box

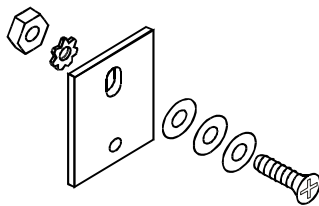

Mounting Tab

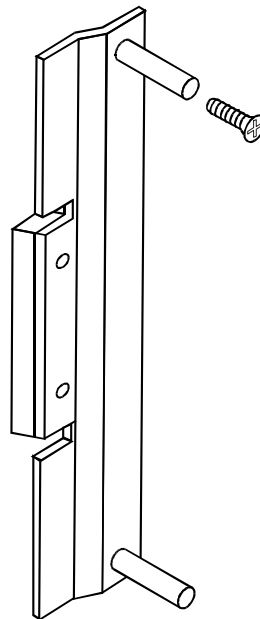

Astragal

700 Strike 700 Series Parts



FOLGER ADAM SECURITY INC.
A member of the Yale Security Group

| Finish | 712 & 732 Faceplates | 712-75 & 732-75 Faceplates |
|--------|-------------------------|-------------------------------|
| US3 | 012-0600-002 | 012-0615-002 |
| US4 | 012-0600-003 | 012-0615-003 |
| US10 | 012-0600-004 | 012-0615-004 |
| US10B | 012-0600-005 | 012-0615-005 |
| US26 | 012-0600-006 | 012-0615-006 |
| US26D | 012-0600-007 | 012-0615-007 |
| US32 | 012-0600-009 | 012-0615-009 |
| US32D | 012-0600-010 | 012-0615-010 |

| Finish | FH PHIL MSC 12-24 x 1/2 UC Mounting screws | FH PHIL WSC 12 x 3/4 UC Mounting screws |
|--------|--|---|
| | Used on: 712, 712-75, 722, 722-75 | Used on: 732, 732-75, |
| US3 | 002-2301-039 | |
| US4 | 002-2301-031 | 002-2300-019 |
| US10 | 002-2301-032 | 002-2300-020 |
| US10B | 002-2301-033 | 002-2300-021 |
| US26 | | 002-2300-022 |
| US26D | | 002-2300-023 |
| US32 | 002-2301-036 | |
| SST | 002-2301-037 | |

| Finish | 722 Faceplates | 722-75 Faceplates |
|--------|-------------------|----------------------|
| US32 | 012-0601-006 | 012-0617-009 |
| US32D | 012-0601-007 | 012-0617-010 |
| DUR | 012-0601-008 | 012-0617-011 |

| Finish | 700 Astragal Assembly | Astragal FH 12-24 x 1-1/4 UC Mounting screws |
|--------|-----------------------------|--|
| | US4 | 076-0825-001 |
| US10 | 076-0825-002 | 076-0803-362 |
| US10B | 076-0825-003 | 076-0803-363 |
| US26 | 076-0825-004 | 076-0803-364 |
| US26D | 076-0825-005 | 076-0803-364 |
| US3 | 076-0825-011 | 076-0803-361 |

| Finish | Mounting Tab set w/screws |
|--------|------------------------------|
| BRS | 076-0803-001 |
| US10 | 076-0803-002 |
| US10B | 076-0803-002 |
| US26 | 076-0803-003 |
| US26D | 076-0803-005 |

| 700 Junction Box Hole Plug | |
|-------------------------------|--------------|
| Size 7/8 | 005-1202-003 |

| Model | 700 Junction Boxes |
|---------|-----------------------|
| 712&722 | 076-0818-001 |
| 732 | 012-0818-002 |

700 Wiring Diagrams

Attachment of New Rectifier

(Required when supplying AC power to a unit with a DC solenoid)

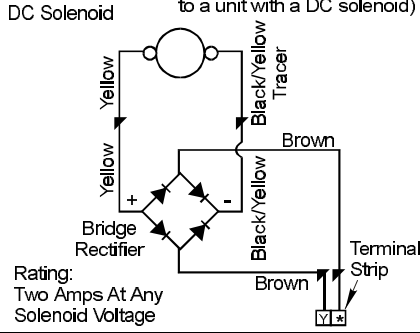

Attachment of Old Rectifier

(Required when supplying AC power to a unit with a DC solenoid)

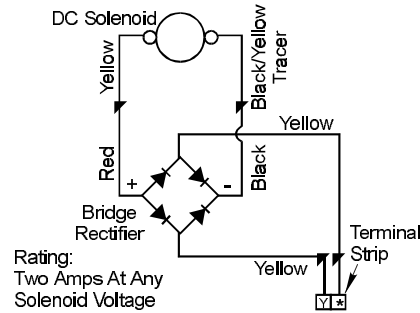

700 LBMLCM Wiring Diagram

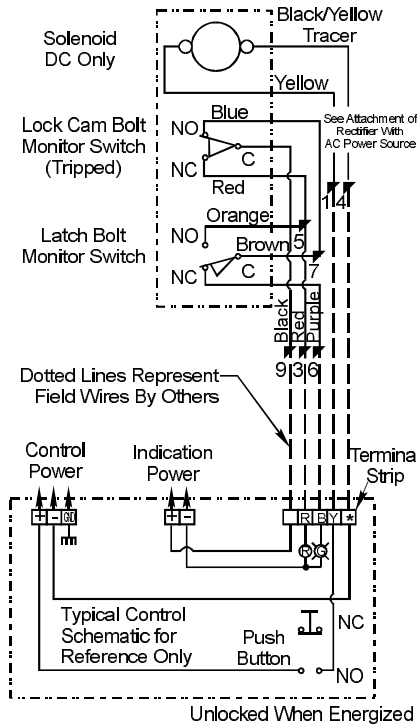

700 LCMA Wiring Diagram

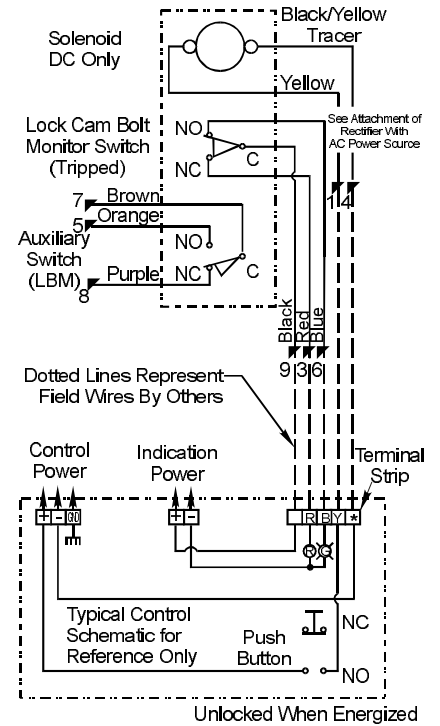

| Electrical Ratings for All 700 Strike Solenoids | Voltage | | | | | |
|---|---------|------|------|------|------|------|
| | DC | | | | | |
| | 6 | 12 | 16 | 24 | 48 | 120 |
| Resistance in OHMS ± 10% | 10 | 41 | 73 | 160 | 640 | 3700 |
| Watts | 3.60 | 3.48 | 3.52 | 3.60 | 3.60 | 3.84 |
| Amps | .6 | .29 | .22 | .15 | .075 | .032 |

Notice:
 Wiring Subject To Change without Notice. Not Responsible when Controls Furnished By Others.

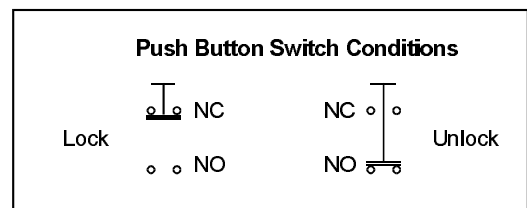

700 Wiring Diagrams

700 LBM Wiring Diagram

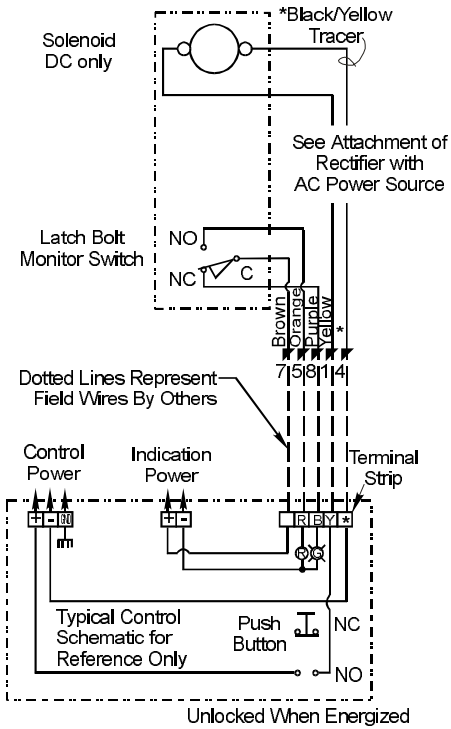

700 LCM Wiring Diagram

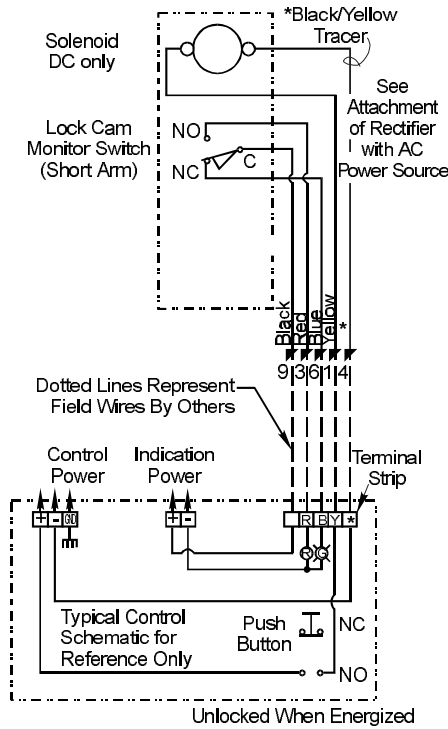

Fail Safe Controls

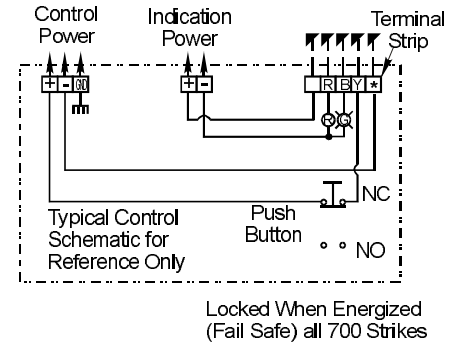

Optional 9-Pin Field Wiring Conn.

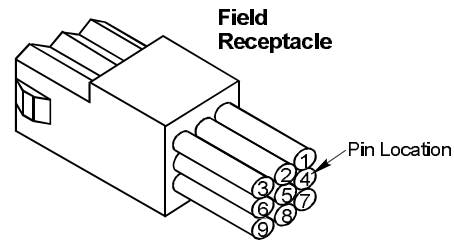
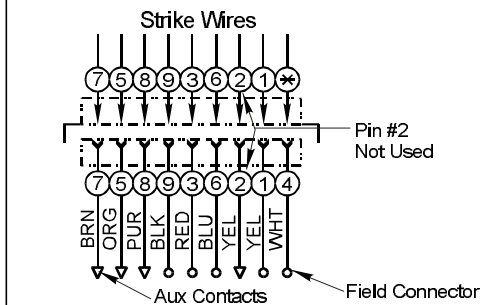

Installation Must Be Properly Grounded Per National Electrical Code Article 250

NOTES:

- * = Wires color code:
6 thru 120 VDC
Yellow/Black Tracer
12 & 24 VAC-Grey
120 VAC-White
- Unused wires to be individually isolated with a wire nut or equal.
- Numbered field connections refer to pin location in field receptacle.