

**FRAME PREPARATION (RH / LHRB FRAME SHOWN)**

Drawing shows ANSI mortise lock strike prep with face of frame modified for electric strike.

Back box by hollow metal manufacturer, constructed in a manner that will hold it's shape. Minimum material thickness 16 gauge.

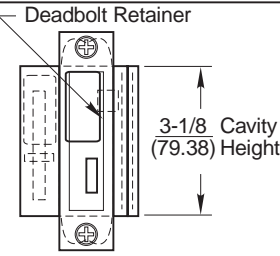
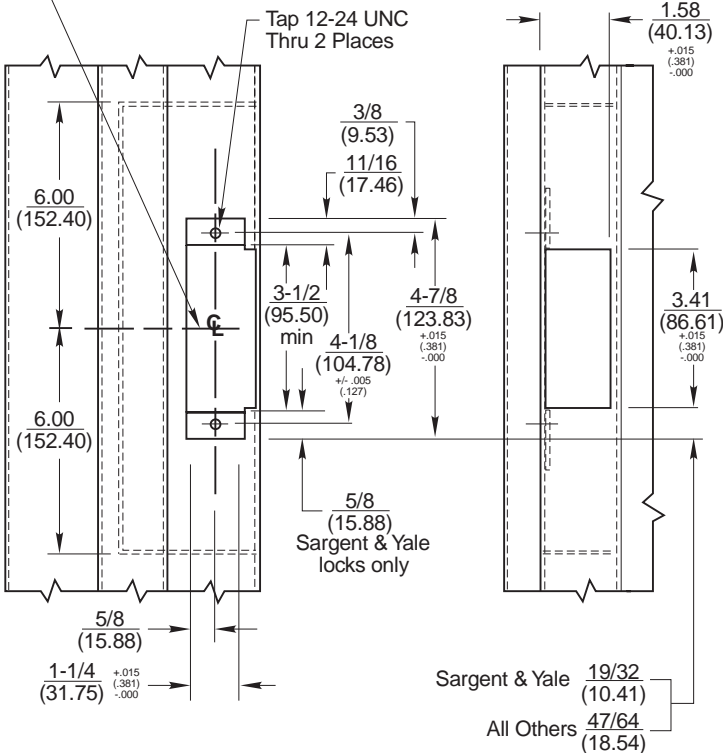
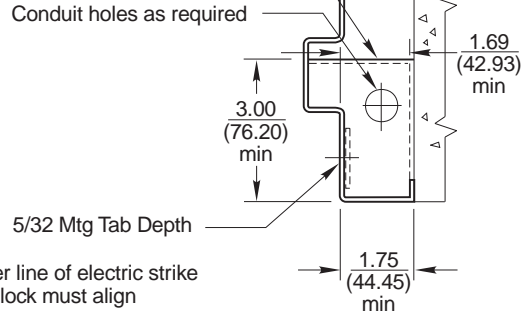

**MODEL 662 RH STRIKE**

For latch & deadbolt combination locksets

**MODEL 652 RH ELECTRIC STRIKE**  
(LH Opposite)

Switch tripper required with optional latch bolt monitor features

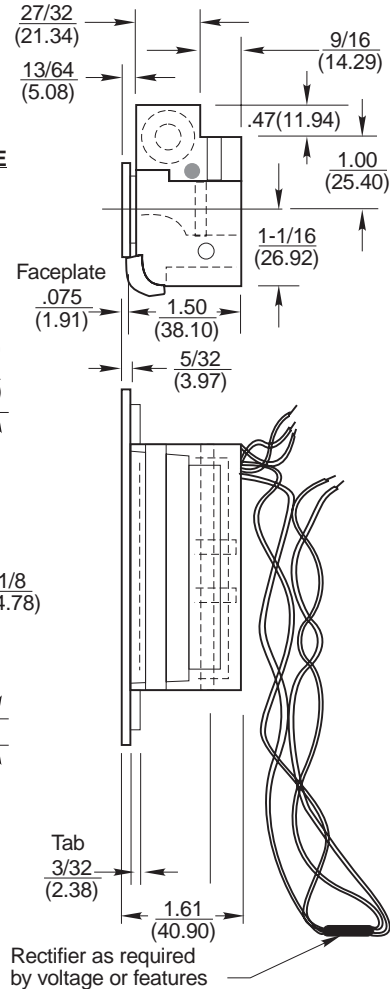
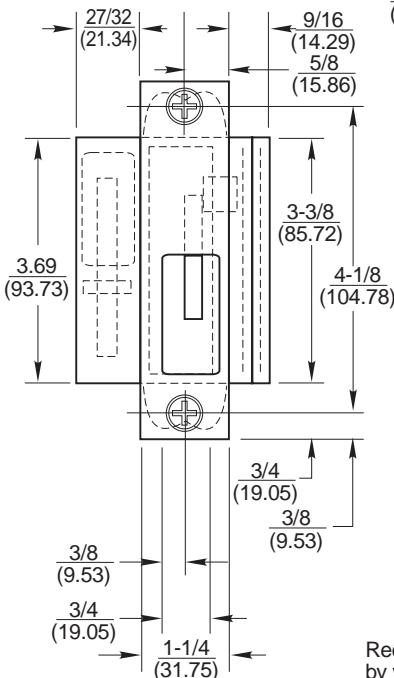

**NOTES:**

1. DO NOT SCALE - All dimensions in inches (mm).
2. Dimensions subject to change without notice.
3. Number of wires will vary per features of strike.
4. All wiring connections to be made opposite the solenoid end of strike. If a rectifier (optional) is used, it may be installed at either end of strike.
5. Wires to be run from end of strike to conduit connection.
6. Cut off all excess wire not required for installation.
7. Keeper position is adjustable. Set strike in desired position behind the faceplate and tighten the mounting screws securely.
8. Refer to catalog for available finishes, voltages, and optional features.
9. Door & frame manufacturers are responsible for providing adequate construction or reinforcements for proper installation of hardware shown.
10. Tolerances shown are for cutouts.
11. Remove all burrs and break sharp edges.

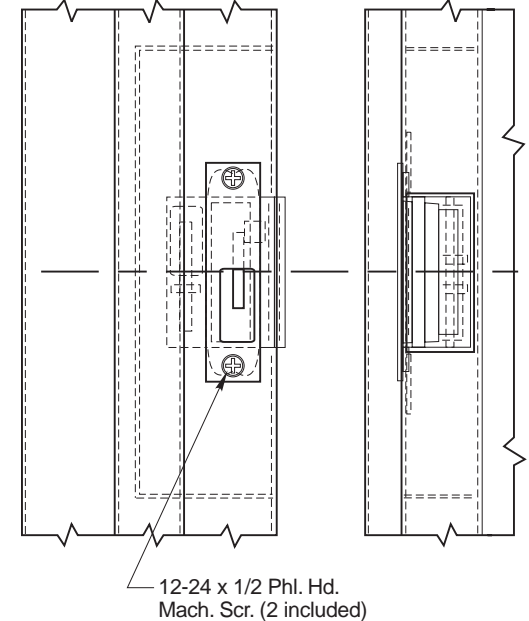

**652-662 RETROFIT**



REF. REPAIR PART DWG.

P.O. BOX 25288, CHARLOTTE, NC 28229-8010

TEMPLATE NUMBER

**092-0250-028**

DATE

**9-98**

**FRAME PREPARATION (RH / LHRB FRAME SHOWN)**

Drawing shows ANSI mortise lock strike prep with face of frame modified for electric strike.

Back box by hollow metal manufacturer, constructed in a manner that will hold it's shape. Minimum material thickness 16 gauge.

Conduit holes as required

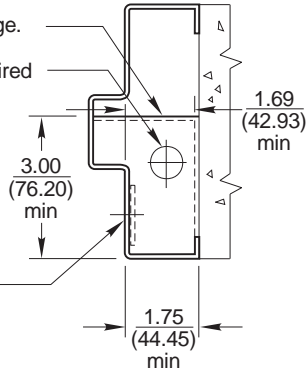

5/32 Mtg Tab Depth

Horizontal center line of electric strike and latchbolt of lock must align

Tap 12-24 UNC Thru 2 Places

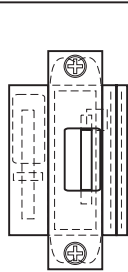
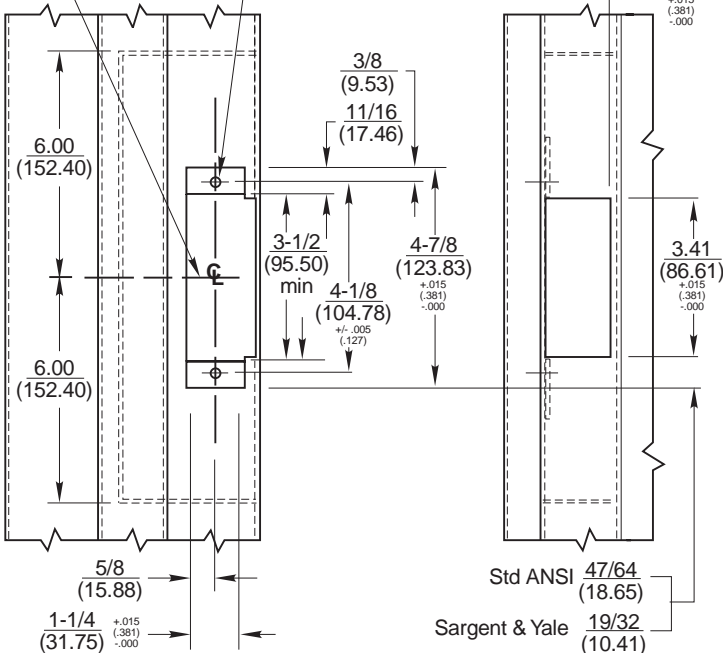

**Model 642 RH Strike**  
For bored / cylindrical locksets only

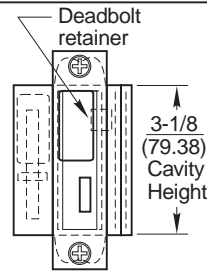

**Model 662 RH Strike**  
For latch & deadbolt combination locksets

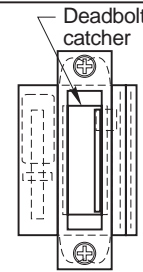

**Model 672 RH Strike**  
For normally extended deadbolt only locksets

**MODEL 652 RH ELECTRIC STRIKE**  
(LH Faceplate Opposite)

Switch tripper illustrated with optional LBM switch. See catalog for all features.

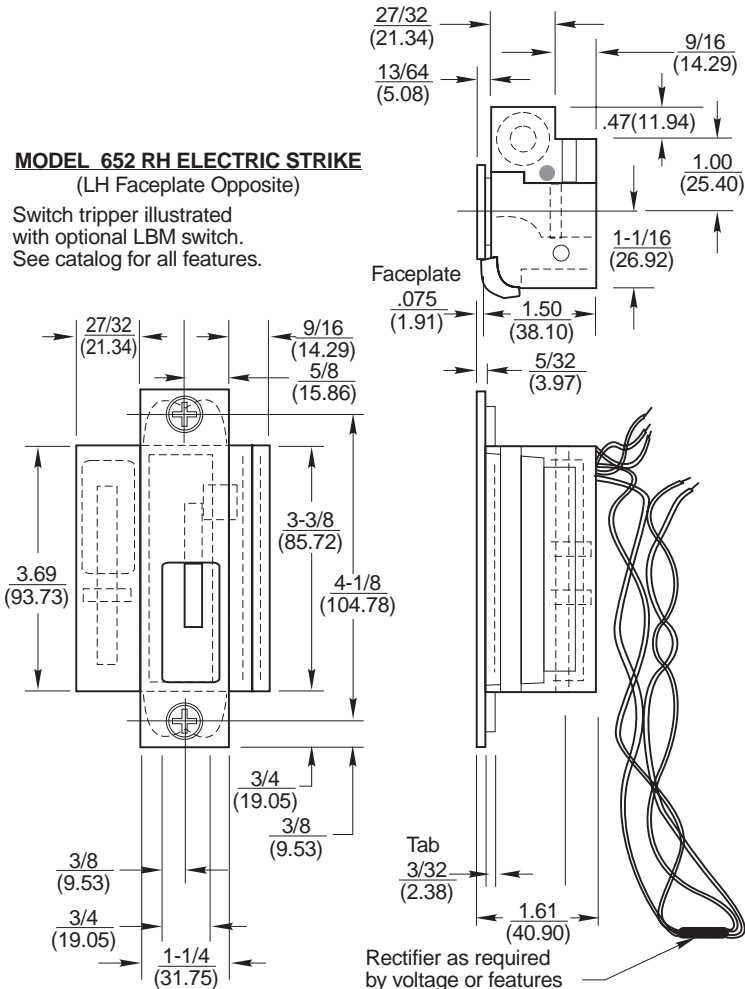

**NOTES:**

1. DO NOT SCALE - All dimensions in inches (mm).
2. Dimensions subject to change without notice.
3. Number of wires will vary per features of strike.
4. All wiring connections to be made opposite the solenoid end of strike. If a rectifier (optional) is used, it may be installed at either end of strike.
5. Wires to be run from end of strike to conduit connection.
6. Cut off all excess wire not required for installation.
7. Keeper position is adjustable. Set strike in desired position behind the faceplate and tighten the mounting screws securely.
8. Refer to catalog for available finishes, voltages, and optional features.
9. Door & frame manufacturers are responsible for providing adequate construction or reinforcements for proper installation of hardware shown.
10. Tolerances shown are for cutouts.
11. Remove all burrs and break sharp edges.

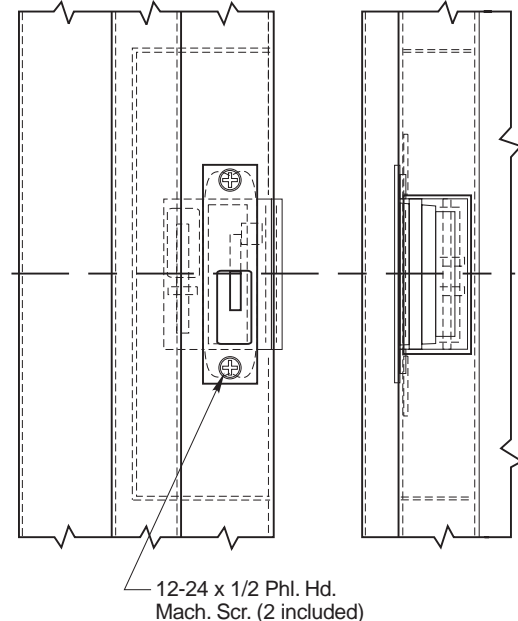

**Standard Prep HM or Alum**  
**642-652-662-672 Electric Strikes**

	REF. REPAIR PART DWG.
	P.O. BOX 25288, CHARLOTTE, NC 28229-8010
TEMPLATE NUMBER	DATE
<b>092-0250-029</b>	<b>9-98</b>