

**26 BIT WIEGAND SPECIFICATIONS**

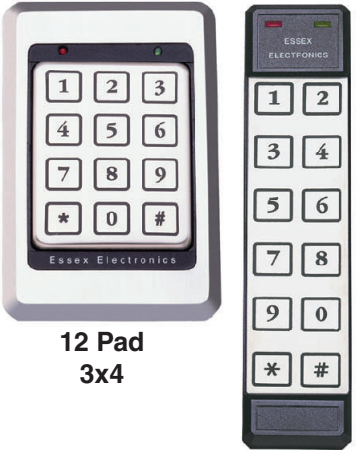

**Part Number (s):** KTP-103-SN, KTP-103-BN, KTP-103-KN  
 KTP-102-SN, KTP-102-LI, KTP-102-BN, KTP-102-LR

**Output:** 26 Bit Wiegand Open Format

**Voltage(s):** 5 VDC, +/- 0.1V 20mA 12 VDC, +/- 3.0V 20mA

**Temperature:** -40 C to +70 C (-40 F to +160 F)

These Keypads are selectable for 5 or 12 Volts. There are two pins directly above the connector on the back of the keypad, A jumper plug is installed on one of the pins. This is the default setting for 12 Volt operation. If you require 5 Volt operation, install the jumper plug on both pins.

DATA 1 and DATA 0 signals are open collector outputs with 2.2K pull-ups to the internal +5v. The data is sent at 1 msec per bit with a pulse duration of 50 usec. An annunciator beeps with each key press. When the LED control input is pulled low, the GREEN LED will be on and the RED LED will be off. When the input goes high the RED LED is on and the GREEN LED is off. The LED that is illuminated, will blink off with every key press. The LED control input is pulled to the internal +5v with a 2.2K resistor. An output is generated with each key press which can be used to drive a CCTV or Security Light. Located through the Blue wire (see Connector Wiring), this is an open collector output capable of sinking 1/4 A with a 30 second on time.

**12 Pad 3x4**

**Thinline 2x6**

The following WIEGAND output is sent each time the # (enter) key is pressed:

P S S S S S S S N N N N N N N N N N N N N N P  
 BIT 1 2 9 10 25 26

BIT 1 is an even parity for the following 12 bits. The sum of bits 1-13 is even.

BITS 2-9 are the SITE CODE.

BITS 10-25 This is the number(PIN) entered prior to pressing # (enter).

Leading 0's are added as required. Bit 10 is most significant.

BIT 26 is an odd parity over the previous 12 bits. The sum of bits 14-26 is odd.

Example: Site Code of 004 and a code of 123 entered 1 0 0 0 0 1 0 0 0 0 0 0 0 0 0 1 1 1 1 0 1 1 1

Note: An error code which sends all binary 1's to your panel is generated by any of the following:

- a) Pressing the # key with no preceding digits.
- b) Pressing any number of only 0's prior to pressing the # key
- c) Pressing 65,535 or any number above 65,535. Do NOT program your panel to accept code number 65,535.

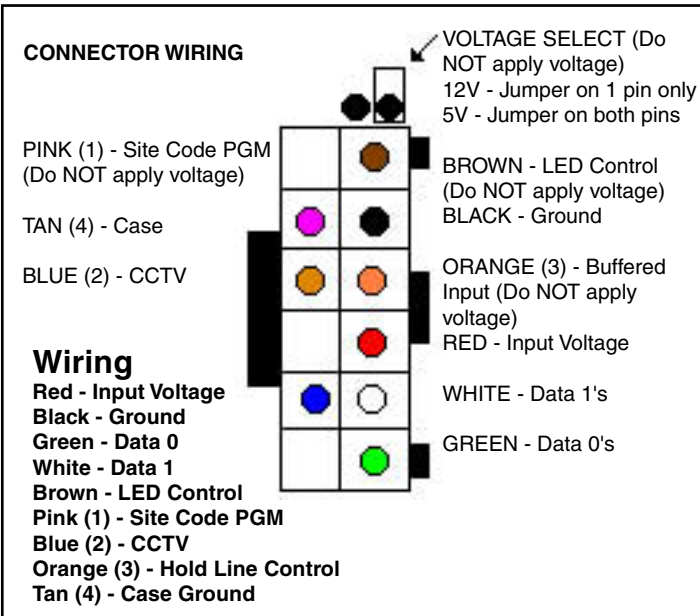

1 PINK - This Keypad is capable of having the SITE CODE programmed in the field. The PINK wire is used for this procedure. With NO voltage applied to the Keypad, connect the PINK wire to the BLACK wire on the wiring harness. Apply the appropriate voltage to the RED and BLACK wires. You will hear 4 rapid audible beeps and both the RED and GREEN LED's will flash at the same rate. Enter the desired SITE CODE (between 0 and 255) on the Keypad and press # for enter. You will again hear 4 rapid audible beeps and see both LED's flash 4 times. At this point the Keypad will appear dead and not accept any entries. (If the wrong key is pressed during the programming sequence, pressing the \* key will clear the entry. You will then hear 2 rapid beeps and both LED's will flash at the same rate. The Keypad will generate an error tone if you enter a SITE CODE over 255.) Disconnect power to the RED wire and disconnect the PINK wire from the BLACK wire. Now you can connect the standard Wiegand 5 wires to the Keypad and the programmed SITE CODE will be generated as part of the 26 Bit data when the enter key (#) is pressed. This procedure may be repeated to change the SITE CODE. Factory default is 000.

2 BLUE - Pressing any position on the Keypad will generate a 30 second 0.25 amp intermittent duty grounding output.

3 ORANGE - When the Hold Line, ORANGE wire, is pulled "low", codes entered on the Keypad are stored in the buffer. When the Hold Line is released to a logic "high", the buffered code is sent. This input is pulled "high" with a 2.2K resistor.

4 TAN - Case Ground at the Keypad installation point, not through the cable.

UL Listed: Access Control Unit Accessory - 43J0  
 CE Compliance: EN-55022:1994, Class B  
 EN-50082-1: 1992

This device complies with Part 15 of the FCC rules and regulations.

Operation is subject to the following two conditions: (1) This device may not cause harmful interference, (2) this device must accept any interference including interference that may cause undesired operation.

NOTE: The Thinline 2x6 Keypad has two LED's that are used for illumination. To turn on illumination, cut the wire loop by the connector. Activating illumination will draw an additional 20 mA.