

COBRA

BY SCHLAGE

Installation Instructions and Users Manual

MPM & MPMA MORTISE LOCKING SYSTEM



Manually Programmed Mortise Lockset. Up to 100 codes can be manually programmed.

MPM

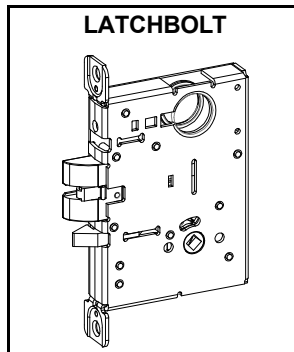

MPMA

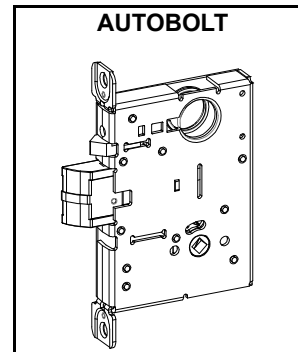

2. CHANGE LOCK HAND (IF NECESSARY):

NOTE: The locks are shipped as ordered from factory. If it is necessary to change the hand of the lock, follow the steps below:

TO CHANGE HAND OF LOCK CASE:

- A. With bolt fully extended, insert change pin (included in the hardware pack) into hole. (It will snap over a groove on the main shaft, holding it in place.)
- B. Remove set screw in bolt so bolt can be removed.
- C. Rotate bolt and reinstall on to shaft. Do not remove spring.
- D. Apply thread locking compound to set screw.
Loctite 242 recommended.
- E. Install and tighten set screw (from other side, as shown).
- F. Remove change pin.

TO CHANGE HAND OF LEVERS:

- A. Loosen 5/32" socket cap screw and remove lever.
- B. Rotate handle to opposite position.
- C. Apply thread locker to screw. Loctite 242 recommended.
- D. Reinstall handle.
- E. Repeat for inside escutcheon (not shown).

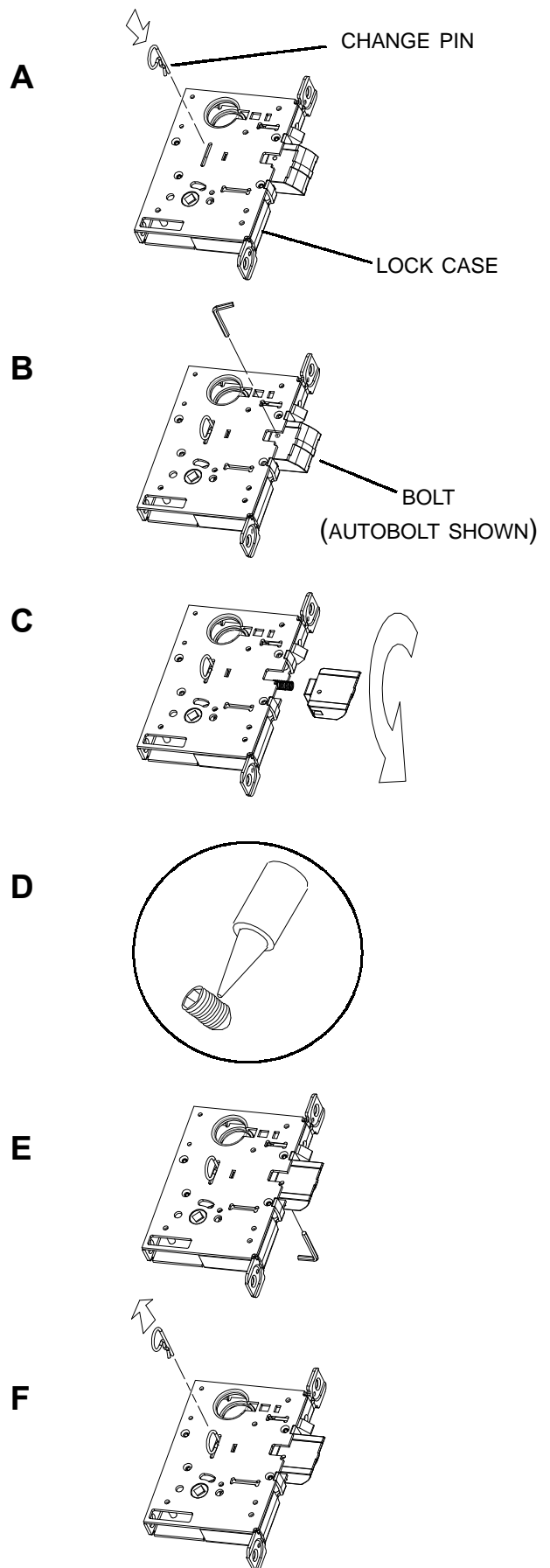
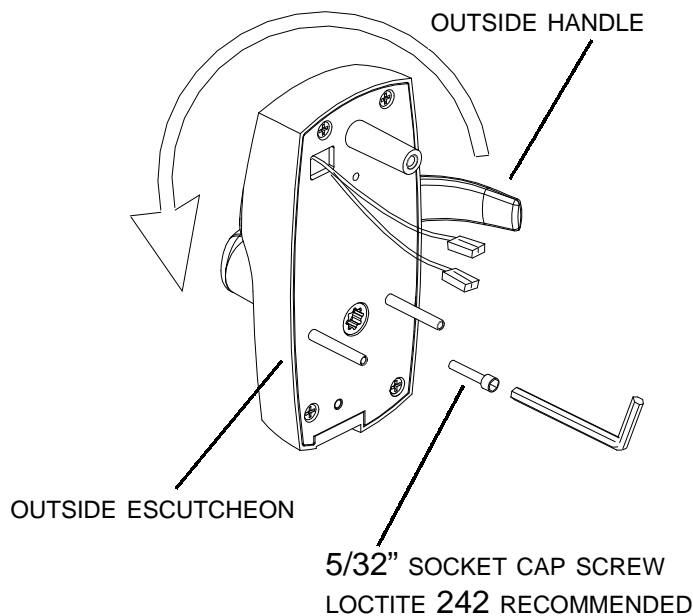

3. INSTALL MORTISE LOCK:

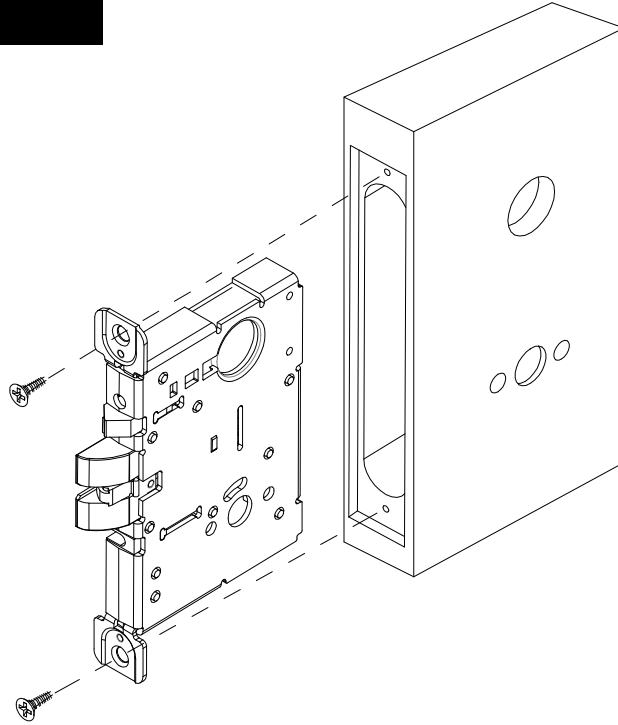

4. INSTALL STRIKE:

STRIKE SUPPLIED WITH PRODUCT MUST BE USED FOR PROPER OPERATION.

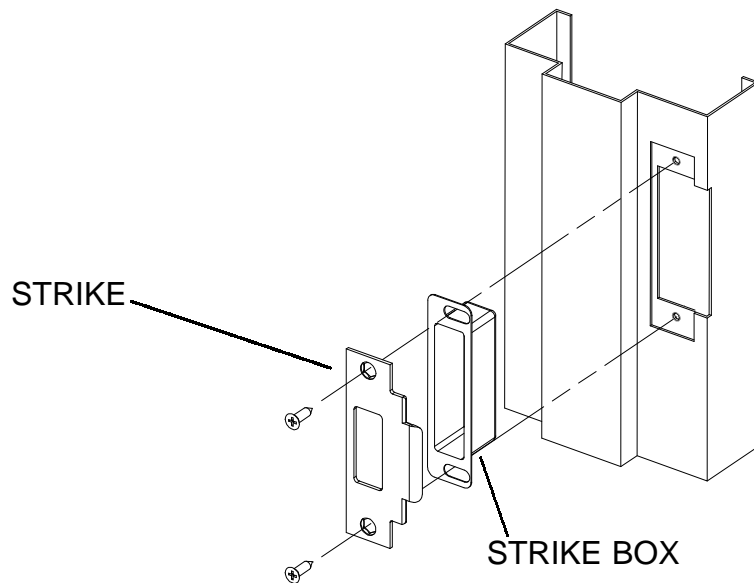

5. INSTALL OUTSIDE SPINDLE & ESCUTCHEON:

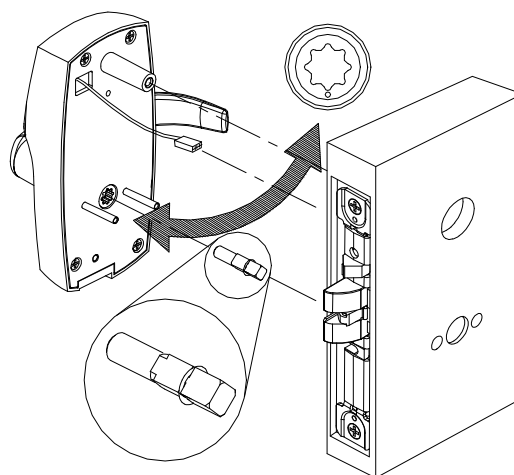

6. INSTALL INSIDE BASEPLATE ASSEMBLY:

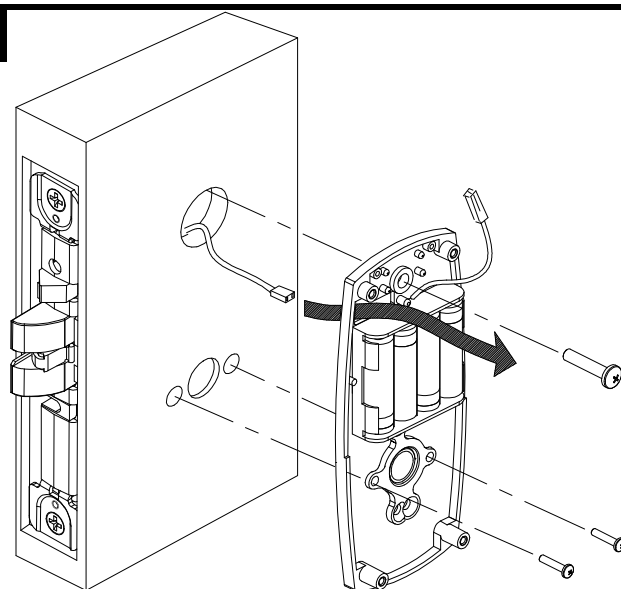

7. INSTALL 6- or 7-PIN IC CORE CYLINDER (RECOMMENDED):

NOTE:
 6-PIN IC CORE CYLINDERS REQUIRE THAT THE ADAPTER IS INSTALLED TO MAKE THEM AS LONG AS A 7-PIN CYLINDER. THE ADAPTER IS INCLUDED IN THE SCREW PACK. DO NOT INSTALL THE ADAPTER IN A 7-PIN IC CORE CYLINDER.

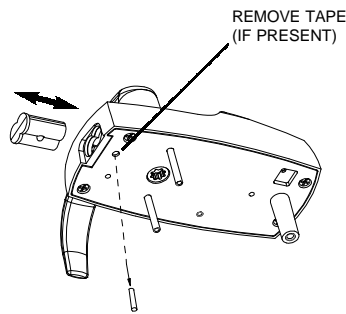
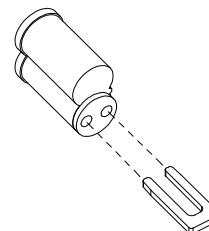

A. HOLD LOCK IN HORIZONTAL POSITION AS SHOWN AND PUSH PLUG IN UNTIL PIN FALLS OUT. REMOVE PLUG.

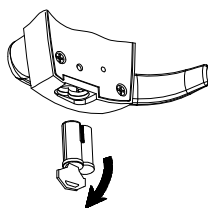

B. INSERT CYLINDER CONTROL KEY INTO CORE AND TURN CLOCKWISE TO RETRACT LOCKING PIN.

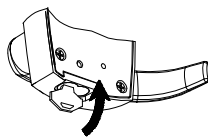

C. PUSH CYLINDER CORE INTO LOCK - RESISTANCE WILL BE NOTICEABLE. TURN KEY COUNTER-CLOCKWISE TO ENGAGE LOCKING PIN.

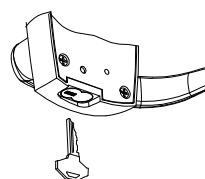

D. REMOVE KEY. LOCK IS NOW OPERATIONAL.

OPERATION:
 EITHER THE CYLINDER PLUG OR THE IC CORE MUST BE INSTALLED FOR THE LOCK TO OPERATE. REMOVAL OF THE CORE OR PLUG AUTOMATICALLY UNLOCKS THE LOCK. IT IS RECOMMENDED THAT AN IC CORE BE INSTALLED IN CASE IT EVER BECOMES NECESSARY TO UNLOCK THE LOCK USING MECHANICAL MEANS.

8. MAKE WIRING HARNESS CONNECTIONS:

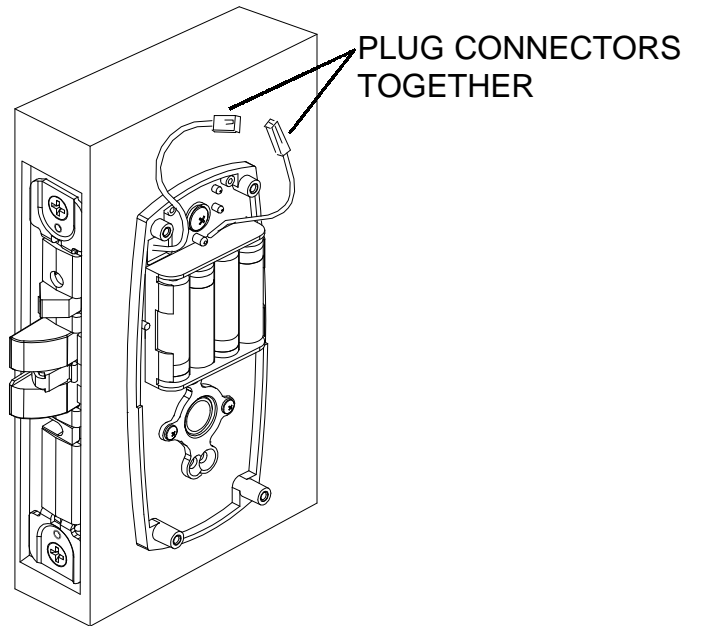

9. INSTALL INSIDE SPINDLE/SPRING AND INSIDE ESCUTCHEON:

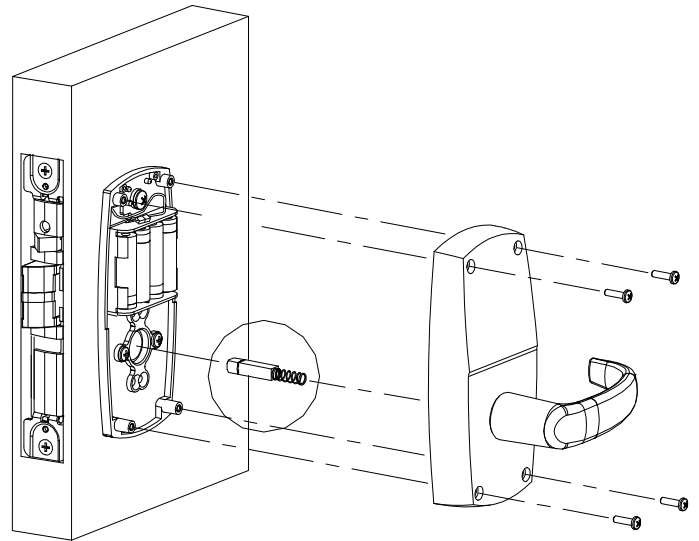
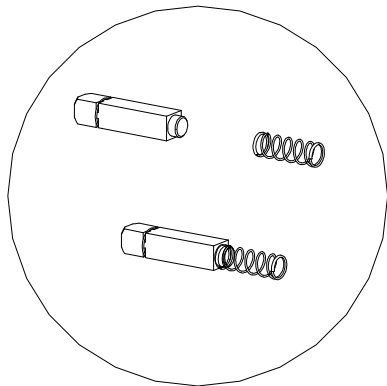

10. INSTALL ARMOR FRONT:

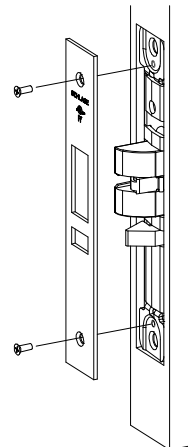

PROGRAM LOCK CODES:

11

Code Functions:

The MPC Cobra is manually programmable to have up to 100 codes. The codes can have different functions as described below. Several types of functions have factory default values which are operational as soon as the lock is installed. It is highly recommended that the *Programming Code* be changed (this will delete all factory default codes) and new codes be added. In addition, it is recommended that at least one *Freeze/Lockout Code* be added - in case the batteries get completely drained. (See "Battery Information" on below.) All codes can be 3-8 digits in length (except the Programming code which must be 5-8 digits.) Keep a log of all issued codes. Issue codes exclusively with all odd or all even numbers - this practice will make it easier to spot duplicate codes, since each keypad button represents two numbers (for example, code 246 is identical to code 135.)

FUNCTION:	FACTORY DEFAULT:	DESCRIPTION:
PROGRAMMING	9 7 5 3 1	The programming code puts the lock into a programming mode. It will not unlock the lock. When a Programming code plus "*" is entered the LEDs alternately flash several times indicating the lock is in a programming mode. If more than 30 seconds pass in between programming entries, the lock returns to a normal operational state.
NORMAL	1 3 5 7 9	Normal codes unlock the lock for the relock time delay. While the lock is unlocked the green LED will flash. The LED will stop flashing and the lock will relock.
TOGGLE	1 3 5 1 3 5	Toggle codes unlock the lock indefinitely. When the same (or another) toggle code is entered, the lock will immediately relock. When a toggle code is entered, the green LED will flash once. The LED will stop flashing and the lock will relock. .
FREEZE/LOCKOUT	9 1 1 5	Freeze/Lockout codes prevent other codes from working. The lock can be locked or unlocked when one is entered. If it is locked, a Pass Thru code will unlock it but all other codes will not. Only another Lockout code will reverse the effect.
ONE USE	NONE	One Use codes unlock the lock for the relock time delay. They will only work once and then are deleted from memory. They can be used again if they are programmed (added) into memory again.
SUPERVISED	NONE	Supervised codes require that two different supervised codes be entered in order to unlock the lock for the relock time delay.
PASS THRU	NONE	Pass Thru codes will unlock the door for the relock time delay even if the door is in the lockout mode.

BATTERY INFORMATION:

The MPC Cobra uses four, standard AA batteries. The batteries should provide enough life for approximately 80,000 lock/unlock cycles. When the batteries are running out the lock provides two different modes of low battery indication: First, when a code is entered, the red LED will flash twelve times before the lock executes the command of the code. This is an indication that it is time to replace the batteries. The lock will go for about 500 cycles in this condition. After it reaches a certain point the lock will go into "Low Battery Lockout" mode. A Freeze/Lockout code will need to be entered in order to gain access. If the batteries are not changed, the lock will eventually not work and manual key override (if installed) will need to be used.

CLEARING MEMORY:

Clearing memory will delete all programmed codes and restore factory default codes. If the memory ever needs to be erased follow the steps below:

1. Remove the inside escutcheon. Remove one of the batteries.
2. Press any key.
3. Hold down the "*" key and reinstall the battery. Continue holding the "*" key down. The red LED will flash a few times and then stay on.
4. Release the "*" key.
5. Install the inside escutcheon.

Note: to return the lock to the factory default relock time delay, do steps 1-4 twice in a row.

PROGRAMMING STEPS:

Use the steps on this page to program codes into the lock. The "*" key is used like the <ENTER> key is on a computer. After pressing the "*" key, wait for the red and green LEDs to stop flashing before proceeding to the next step. If at any time the red LED stays on while the green LED flashes an error has occurred. The flashing message will repeat three times. Count the number of flashes and consult the error code chart below.

FLASHES	ERROR CODE	DESCRIPTION
2		Code too long 8 digits max.
3		Memory full, must delete some codes
4		Can not delete Programming code - use Change steps.
5		Second entry did not match first (Programming Code)
6		Invalid entry, start over. (Verify that any codes entered prior to this error do not operate the lock.)
7		Code to be deleted does not exist.
8		Duplicate code, code already exists.

TO ADD NORMAL USE CODE

ENTER PROG. CODE *
 3 *
 ENTER NEW CODE *
 * *
 TO ADD MORE
 * TO END

TO ADD TOGGLE CODE

ENTER PROG. CODE *
 33 *
 191 *
 ENTER NEW CODE *
 * *
 TO ADD MORE
 * TO END

TO ADD FREEZE/LOCKOUT CODE

ENTER PROG. CODE *
 33 *
 115 *
 ENTER NEW CODE *
 * *
 TO ADD MORE
 * TO END

TO ADD ONE TIME USE CODE

ENTER PROG. CODE *
 33 *
 113 *
 ENTER NEW CODE *
 * *
 TO ADD MORE
 * TO END

TO ADD SUPERVISED CODE

ENTER PROG. CODE *
 33 *
 117 *
 ENTER NEW CODE *
 * *
 TO ADD MORE
 * TO END

TO ADD PASS THRU CODE

ENTER PROG. CODE *
 33 *
 119 *
 ENTER NEW CODE *
 * *
 TO ADD MORE
 * TO END

TO CHANGE PROGRAMMING CODE

ENTER PROG. CODE *
 7 *
 ENTER NEW PROG.CODE *
 * *
 ENTER NEW PROG.CODE AGAIN *
 * *

TO DELETE CODES

ENTER PROG. CODE *
 5 *
 ENTER CODE *
 * *
 TO DELETE MORE
 * TO END

TO CHANGE RELOCK TIME DELAY (DEFAULT 5 SEC.)

ENTER PROG. CODE *
 99 *
 1 *
 PRESS 1 FOR 1 SEC. AND/OR 5 FOR 5 SEC. THE TIMES WILL ADD. 1 *
 5 *
 * TO END